

**AmericanAirFilter®**  
**Air Pollution Control Products**  
**and Capabilities**

*Power and Industrial*

*Advanced Solutions for Air Pollution Control*



*Better Air is Our Business®*

# AmericanAirFilter®

## Air Pollution Control

### Industry Leader

Modern industrial processes produce large quantities of airborne pollutants in all forms — particulates, gases, vapors, fumes, and mists. Many pollutants are toxic, and concentrations can easily exceed safe levels of exposure to workers. Reducing the concentration to acceptable levels identified by the American Conference of Governmental Industrial Hygienists (ACGIH) is a critical factor in the operation of any industrial process.<sup>1</sup>

Design of the overall plant ventilation system must take into consideration a complex series of factors:

- Controlling the level of process generated contaminants
- Employee health and comfort
- Temperature and humidity control
- EPA regulations for discharging polluted exhaust air
- The risk of dust generated explosions
- Cost of the air pollution control equipment
- Cost of the HVAC equipment
- Operating costs of the system
- Supply and exhaust air balance

### Unmatched Product Line and Industry Experience For More Than 85 Years

AAF® International has an unmatched capability to understand complex air pollution control problems, and to develop effective solutions from conception through final installation. Our complete line of equipment allows us to recommend the most efficient and economical solutions, ranging from a completely packaged unit to solve small in-plant dust control problems up to large, complex, custom engineered systems for major air pollution control projects.

Throughout its rich history — more than 90 years, AAF has pioneered many of the techniques and equipment used in air pollution control applications today. AAF's dust, mist, vapor, and fume control products can be found in thousands of installations in virtually every industry and in most industrialized countries around the world.



OptiFlo®

N RotoClone®, above; Millennium™, top

<sup>1</sup>Refer to the ACGIH® Industrial Ventilation: A Manual of Recommended Practice for Design, 26th ed. and 2009 TLVs and BEIs, ©2009 Cincinnati, OH.

## Wet Collectors

AAF pioneered the development of wet collectors, devices designed to remove particulate matter from the air by passing them through a liquid medium. AAF supplies wet collectors for a wide range of applications from small nuisance dust problems to extremely large gas cleaning systems.

### Type W RotoClone®

The Type W RotoClone is designed to combine the scrubbing effect of water with the principle of dynamic precipitation. This highly effective wet-type collector discharges collected materials as a slurry. The Type W collector is effective in applications such as chemical processing, mining, coal processing, food, and pharmaceutical dust capture.

- Sizes available for volumes of 1,000 to 50,000 CFM.
- Minimum water requirement, only 1/2 to 1 gallon per 1,000 CFM of air.

Brochure APC-1-512

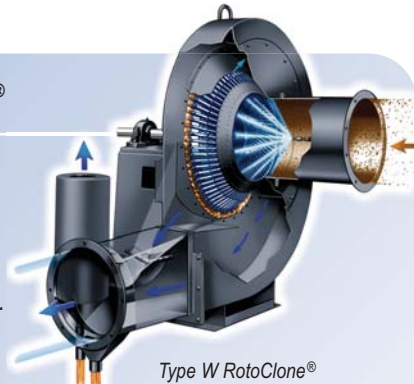

### Type N RotoClone®

The Type N RotoClone cleans the air by the combined action of centrifugal force and a thorough intermixing of water and dust-laden air. It has no moving parts, pumps, or other auxiliary equipment. It requires minimum space and is easy to install.

- Three arrangements available – manual sludge removal, continuous sludge ejection (shown at right), and continuous sludge sluicing.
- Satisfies NFPA requirements for collection of explosive materials such as aluminum, titanium, and magnesium.
- Sizes available for volumes of 1,000 to 50,000 CFM.

Brochure APC-1-511

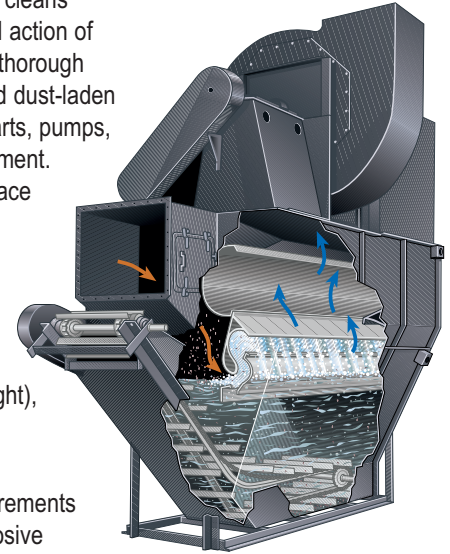

Type N RotoClone®

### KinPactor®

The KinPactor scrubber uses a venturi-type orifice utilizing the principle of impaction for intermixing of dust particles and water. Intermixing is accomplished by rapid contraction and expansion of the airstream and a high degree of turbulence. The KinPactor is used wherever high pressure drop venturis are necessary to collect submicron particulate or exceptionally high efficiency is required.

- Sizes available for volumes of 1,000 to 60,000 CFM.
- Uses 8 GPM scrubbing water per 1,000 CFM saturated gas at the throat.

Brochure APC-1-514

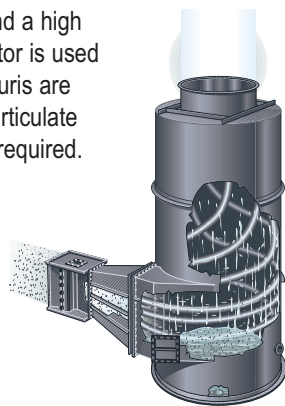

KinPactor®

### Type N RotoClone® Model LV

The Type N RotoClone Model LV dust collector is specifically designed for the ventilation and pollution control of dust emitting machines that require air volumes under 2,000 CFM. The Model LV collector can be close coupled to the dust sources or remotely located with connecting ductwork.

- Available in two standard sizes: 1,000 and 2,000 CFM.
- Suitable for explosive metal (Al, Ti, Mg) grinding and polishing.
- Completely self-contained.

Brochure APC-1-519

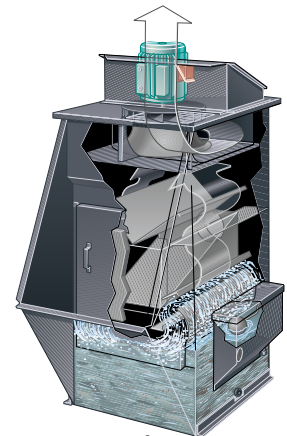

Type N RotoClone®  
Model LV

## Fabric Collectors

One of the universally applied air pollution control devices is the fabric collector which removes particulate matter from the gas stream via filtration through special fabric materials.

### Millennium™

The Millennium combines the most outstanding features of typical baghouses with AAF product development ideas to meet the demands for higher quality air in the 21st century. The Millennium is modular in design, and the modules are available in different heights to accommodate a range of fabric bag lengths, as well as pleated bags.

Since each Millennium is constructed from modules, there is almost no limit to the size of the collector.

Brochure APC-1-405



Millennium™

### Design M FabriPulse®

The Design M FabriPulse pulse-jet fabric dust collector was designed to fill the need of those industrial dust collection applications that require small, compact filter sizes and low air volumes.

- Suitable for low headroom indoor applications as well as outdoor installations.
- Available in sizes from 100 to 1,500 square feet of cloth area.
- Features bag lengths of 4 or 6 feet.
- Side bag removal.



Design M FabriPulse®

Brochure APC-1-411

### ArrestAll® AR Series

The AAF ArrestAll self-contained dust collector is a shaker-type fabric collector which offers a cost effective, compact solution to dust control problems.

- Economical to operate, simple to maintain.
- Requires minimum floor space.
- Air cleaning efficiencies of 99+% by weight.
- Permits recirculation of the air back to the work area in almost all cases with modular filter section.



ArrestAll®

Brochure APC-1-240

## Cartridge Collectors

Cartridge collectors utilize multiple cartridges made of pleated media in a cylindrical configuration. Highly effective on dry particulate, cartridge collectors are among the most popular of the collector designs available today. All OptiFlo products use AAF manufactured filter cartridges for maximum performance.

### OptiFlo®

The OptiFlo cartridge collector system is a completely modular design that allows an unlimited range of sizes. Modules can be interconnected to accommodate the largest air cleaning task. The compact modules conserve valuable space. OptiFlo units have the lowest flange-to-flange pressure drop, allowing up to 10% greater airflow with lower fan horsepower than competitive models.

The internal construction of the OptiFlo prevents direct impingement of entering particulate on the cartridges, minimizing abrasion and dust build up. The top entry, "downflow" design eliminates "can velocity" concerns. A wide selection of cartridge types, options, and accessories enable the collector to be tailored to specific application requirements. Choose from top or front inlet and side or bottom outlet arrangements.

Brochure APC-1-102

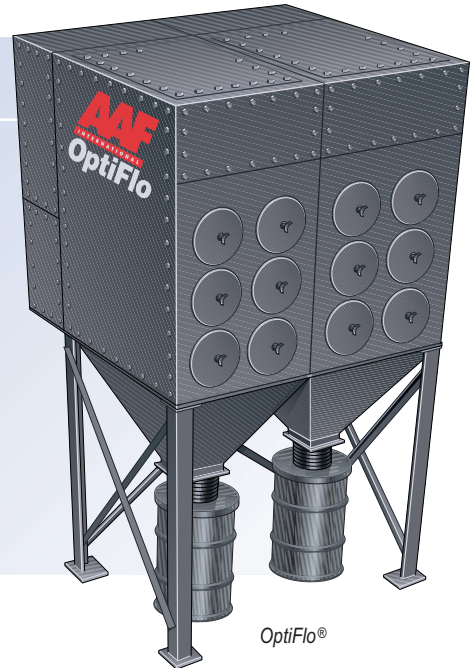

### OptiFlo DustCatcher®

The DustCatcher is a compact, self-contained cartridge collector designed for lower air volume applications. The cartridges are automatically cleaned by reverse pulsing.

- Variety of arrangements and sizes available with capacities up to 2,300 CFM.
- Designed to serve a single source or a ducted system of multiple sources.
- Full size doors allow for easy cartridge replacement.
- High-efficiency final filters available for recirculating processed air back into the plant environment.



OptiFlo DustCatcher®

Brochure APC-1-130

## Mist Collectors

### DynaPure®

The DynaPure mist collector is a self-contained filtration system for source control of mist created by wet machining, spraying, and lubrication systems. It is a unique, simple method for the elimination of mist problems. A rotating drum collects and agglomerates the mist particles – even submicron particles – in its filtering element. Centrifugal force then drives these particles from the airstream. Units with capacities from 25 to 1,000 CFM are available.

Brochure APC-1-222



DynaPure®

## Side Access Filter Housings

AAF makes a variety of Side Access Filter Housings and systems for removing airborne particulate. The housings are designed to address many diverse applications: protection of heating and cooling coils, protection of electrical control rooms, after-filters for dust collectors, preventing the spread of bacteria, or removing odors or gases from the airstream, just to name a few. The housings are designed to be used in conjunction with AAF's wide variety of filters with varying efficiencies. AAF can match the application with the proper housing and filter to ensure that the correct degree of efficiency is provided.

### Bag In/Bag Out Side Access Housing

A multi-stage high efficiency filtration system, the AAF Bag In/Bag Out side loading filter system is a safe, simple, reliable method for removing contaminated particulate filters and/or gas absorbers used for air purification in hazardous environments. With this system, maintenance personnel are protected from coming in direct contact with the interior of the housing and hazardous contaminants during filter change-out. The Bag In/Bag Out system is designed for use in any facility requiring optimum levels of safety and product integrity.

- Housings are available for 12", 16", and 18" adsorber filter cells.
- Each housing is designed in accordance with ANSI/ASME N 509 and N 510, to ensure overall housing integrity.
- Each HEPA filter and adsorber filter seals against the air entering face of the frame to prevent interior contaminant build-up.

Brochure APC-1-260

### Roll-O-Matic®

The Roll-O-Matic automatic renewable air filter is a heavy duty, vertical, automatic roll filter engineered for use with air handling units or other side access equipment. The Roll-O-Matic offers a low maintenance alternative to an initial stage of filtration and is ideal for installations with limited headroom.

- Roll-O-Mat® filter media are the most widely used and most dependable in the industry.
- Fiberglass and synthetic media.
- Modular vertical sections.
- Wide range of Roll-O-Matic sizes.



Side Access Filter Housing, Leverlock shown



Bag In/Bag Out



Roll-O-Matic®

## Services

### Air Pollution Control Installation Group

AAF's APCI Group offers comprehensive installation and service solutions ranging from start-up to full turn-key programs. Drawing on vast air pollution control experience and proven technology, our engineers and technicians provide the innovation and excellence you have come to expect for even the most difficult air cleaning problems. Call on our consultants to deliver complete solutions for specialized and unique applications, as well as basic inspections and analysis to solve routine air cleaning problems.

#### Technical Services:

- Licensed professional engineers on staff
- Project management
- Installation supervision
- Equipment start-up
- Testing
- Application review and analysis
- Site and equipment surveys
- Engineering and design services including full system design

#### Installation Services:

- New equipment
- Full turn-key installation of AAF equipment
- Equipment upgrades and refurbishment
- Guaranteed solutions for air cleaning problems



AAF's APCI Group offers extensive experience with numerous applications and industries to ensure our customers receive and maintain a dependable, quality system that meets their exact air quality requirements and complies with existing regulations.



Do you have a unique application? AAF expert engineers are ready to design a custom solution to meet your particular air quality requirements.

### Custom Solutions for Unique Applications

AAF customers all over the world benefit from our custom designed solutions including ventilation filtration systems for encapsulating biological threats for the United States Postal Service; high efficiency air cleaning systems for secure applications such as embassies, safe rooms, and high value target protection; indoor firing range air cleaning systems; inlet air cleaning for fine bubble diffusers in wastewater treatment plants; and explosive dust containment in industrial applications, to name a few.

### AAF Genuine Parts

Each AAF air pollution control product is designed for cost-effective, reliable performance. Manufactured to the same high quality ISO Standards as our original equipment, and guaranteed to fit and work perfectly, AAF replacement parts help maintain the integrity of your AAF equipment. To protect your investment and ensure maximum performance, insist upon genuine AAF replacement parts and service.

# AmericanAirFilter®

## Air Pollution Control

### Other Products

#### Replacement Filters and Cartridges

AAF brand replacement filters: cartridges, bags, and panels are available for most types of industrial dust collectors and all manufacturers. Our filters are designed for optimum filtration efficiency and long-lasting life. All AAF replacement filter products are built to strict ISO Standards and engineered to withstand the rigors of rugged industrial environments. AAF makes the best and replaces the rest.



Brochure APC-1-550

#### Cyclones

AAF Cyclones have integral fans located on the clean air side for safety and ease of maintenance. High inlet velocity and a long tapered cone design provide excellent performance for removal of airborne dusts generated in woodworking, plastic cutting, grinding, and polishing operations. Models are available from 800 to 12,000 CFM.

Brochure APC-1-271

#### AmerDuct

AAF offers a complete line of quick-fit, clamp together duct and fittings to connect the dust collector to the process hooding with built-in cleanout capability. Available in galvanized and stainless steel construction, the clamp-together ducting simplifies installation and fit, while providing the customer with an easily changeable and moveable installation. Duct and fittings are available in sizes 3" to 24" diameter. Larger, flanged ducting is also available.

#### Environmental Control Modules

The AAF ECM Series, for small rooms and booths, is designed to pull air through the work area and into the filtration system and recycle the air back into the plant. The high-efficiency cartridge filters trap the dust from manufacturing operations, like sanding, routing, sawing, polishing, and welding. Automatic pulse cleaning is standard, and the pulse timing is adjustable. The modules can be ordered in a variety of configurations and CFM ratings to meet your needs.

#### AAF Control Center

The AAF Control Center assures that the entire control package is designed to stop and start your equipment in the sequence required for optimum system performance. The Control Center includes items and components factory prewired to terminal blocks requiring only field connections to external devices. Custom configurations are also available should you have specific job or operational requirements.



The AAF Control Center is complete with the standard controls necessary for your equipment. The standard control enclosure is NEMA 4. Alternate enclosure ratings are available.

Accessories for extra starters and options, including PLC controllers, are available. UL or ULC certification and labeling are standard options.

[www.aafintl.com](http://www.aafintl.com)  
800.477.1214

**AAF**® 10300 Ormsby Park Place Suite 600  
Louisville, Kentucky 40223-6169  
[www.aafintl.com](http://www.aafintl.com)  
Customer Service 800.477.1214  
Fax 800.254.3019



AAF has a policy of continuous product research and improvement and reserves the right to change design and specifications without notice.

ISO Certified Firm