



AmericanAirFilter®
FabriPulse® Design M

FabriPulse® Design M

Performance and Economy in a Compact Package

The Design M FabriPulse pulse-jet dust collector meets the needs of industrial dust collection applications that have low air volume and require small, compact filter sizes. It is engineered to give years of efficient service and minimum downtime in continuous duty dust collection applications.

When combined with the optional integral fan and final filter, the Design M dust collector is a completely packaged air filtration system that allows recirculation of cleaned air.

Benefits

Clean Air

Provides continuous dust collection at 99+% efficiency.

Energy Savings

Fine multi-denier polyester fabric allows low operating pressure drop. Compressed air requirement is minimal. Optional final filter allows recirculation, eliminating the need for conditioned make-up air.

Low Maintenance

Operation is continuous and fully automatic. Complete 42-bag cartridge can be replaced in minutes.

Saves Space

Compact design utilizes unique, small diameter filter bags with built-in venturis and expanders to pack up to 1,500 square feet of media into a small space.

Long Service Life

The rugged design and 12-gauge construction, premium quality bag fabric, and superior cleaning system mean many years of trouble-free service requiring minimal maintenance.



Design M FabriPulse

Principles of Operation

- 1) Dust laden air is drawn through the inlet and impacts the inlet baffle causing heavier dust to fall directly into the hopper. The incoming air is distributed over the fabric surface.
- 2) The air is drawn through fabric filtering bags with the dust collecting on the outside of the bags. The collected dust forms a "cake" that increases the filtering efficiency.
- 3) Cleaned air flows from the bags and is discharged.
- 4) The filter bags are reconditioned with pulses of compressed air. A solid-state electronic timer initiates the pulses. This pulse of low volume, high pressure air is directed from the surge tank through the pulse pipes located above the bags, expanding the fabric and breaking the dust filter cake loose. The dislodged dust falls to the hopper below.

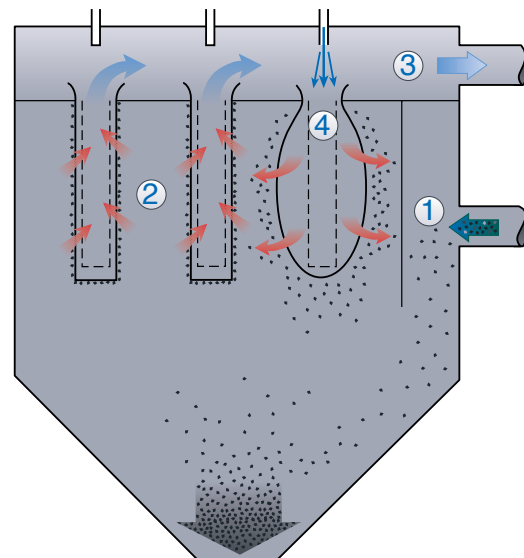

Features

Multi-Denier Polyester Media

The Design M dust collector uses 16 oz. fine denier stratified (needlefelt) polyester that enables a 99+% collection efficiency, high operating air-to-cloth ratio, and excellent dust cake release at minimum pressure loss. Bag lengths are 4 and 6 feet, with other fabrics available.

Solid-State Control

A solid-state electronic timer initiates pulse-jet reconditioning of the fabric filters. The timer is adjustable for both pulse interval and duration. An electronic differential pressure switch is also available. It initiates bag cleaning only when the pressure drop reaches a preset level. This minimizes compressed air usage and maximizes bag life.

42-Bag Cartridge

Each cartridge assembly of 42 bags can be replaced in minutes. The cartridge assembly is removed by releasing the sealing levers and sliding out the tube sheet header. Venturis and cages are built into the bags to reduce maintenance costs.

Two Basic Arrangements

All Design M FabriPulse dust collectors are available in the standard configuration with 45° or 60° side slope hoppers and in the standard bin vent configuration.

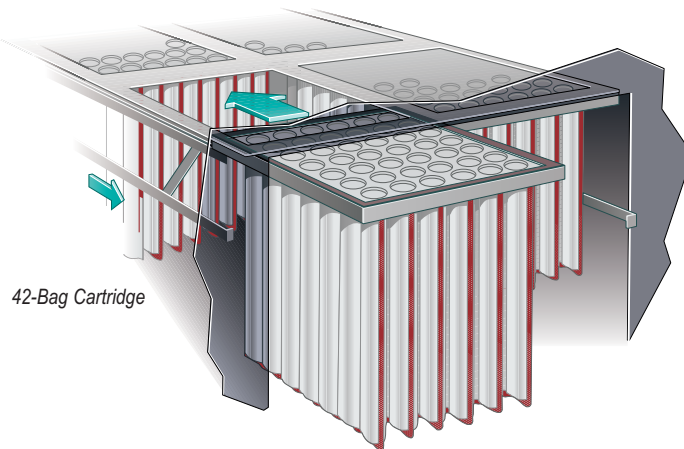
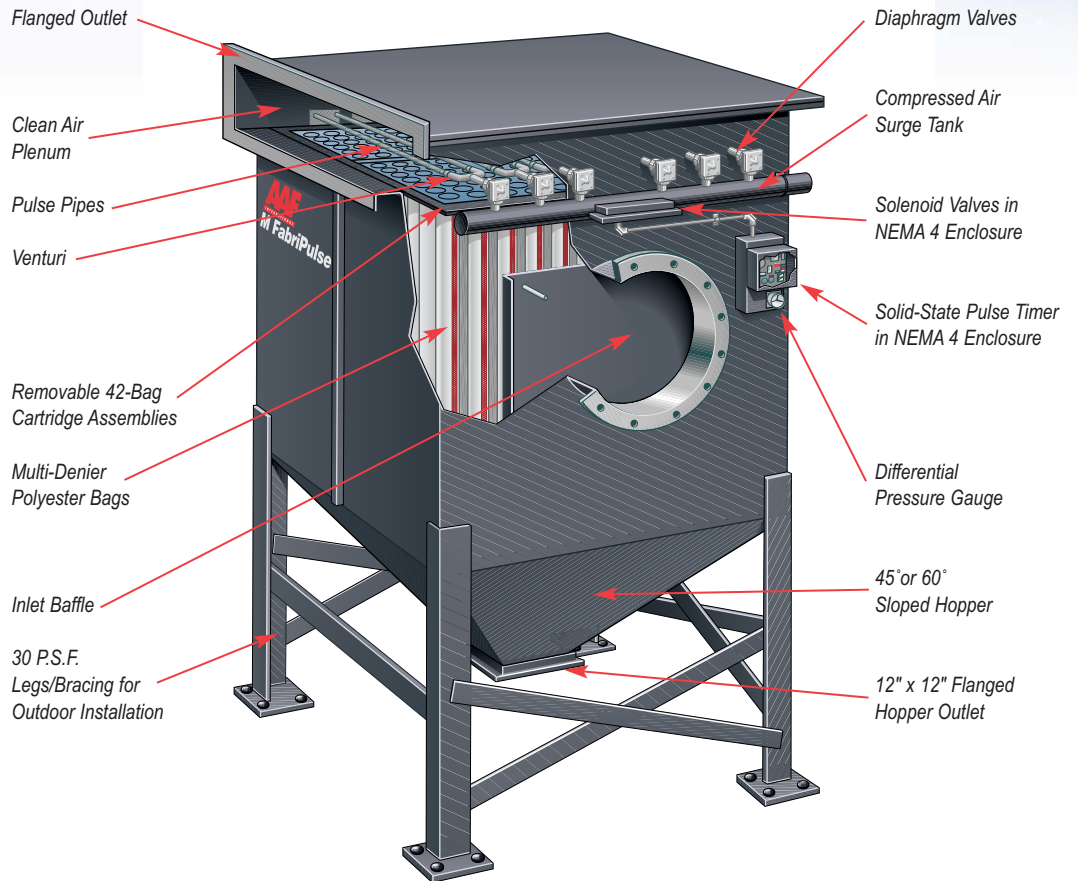

World-Class Quality

Many of the technologies used to control air pollution were originally developed by AAF. During the entire production process, our operations are governed by our **ISO 9001** certified quality system.



Solid-state Electronic Timer

Energy Efficient

Normally, less than 1.0 SCFM of clean, dry compressed air will be required for each 1,000 CFM of dust-laden air. Actual requirements will vary with the dust loading, air-to-cloth ratio, and specifics of the application. Air-to-cloth ratios normally vary between 3:1 and 8:1, depending on the physical and chemical properties of the dust.

Pressure drop across the collector is fairly constant as a result of continuous cleaning of the bags. Pressure drop will vary with the air-to-cloth ratio, temperature of the gas stream, dust loading, and characteristics of the dust. Normally, pressure drop will range from 3" to 6" w.g.

FabriPulse® Design M

FabriPulse® Design M Dust Collector (with Integral Fan)

High Efficiency Fans

The non-overloading, backward inclined fan system delivers more air at higher static pressures and reduces capacity variation and suction loss as the dust cake builds.

Built-In Silencer

All Design M collectors with the integral fan option have built-in silencing to comply with OSHA noise limits.

- Requires less floor space than mounting the fan externally from the collector
- No fan pedestal required
- Eliminates interconnecting ductwork

Optional Final Filter

With the optional integral fan and final filter, the Design M dust collector is a completely packaged clean air system allowing recirculation of cleaned air.

FabriPulse® Design M (Bin Vent)

- Full size range available
- For bins and silos
- Outlet weather hood with bird screen optional

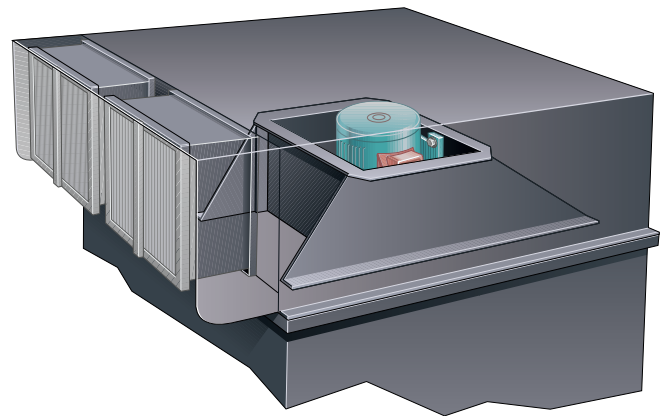
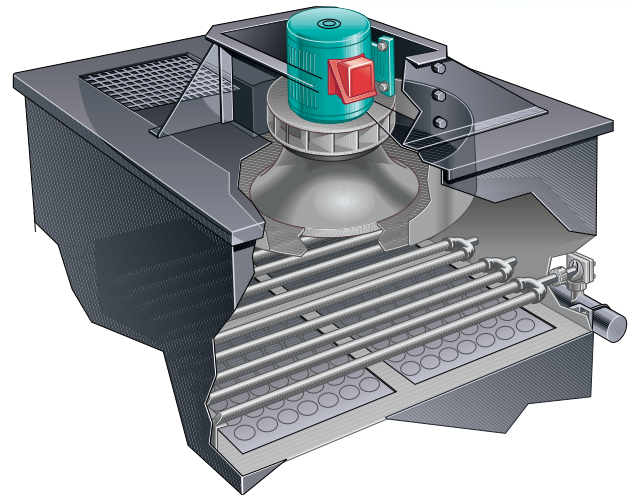

Applications

Food Processing

- Cereals
- Candy
- Chocolate & Cocoa
- Flour & Mixes
- Dog & Cat Food
- Seasonings & Additives
- Milk Solids
- Nut Shells
- Starch

Industrial Processes

- Plastics & Rubber
- Rock & Related

Products

- Coal Dust
- Paint Pigments
- Pesticides/Fertilizer
- Inorganic Chemicals
- Tobacco
- Carbon Black
- Foundry Shakeout

Woodworking

- Furniture Manufacturing
- Cabinetry

Pharmaceutical

- Material Handling
- Packaging
- Bulk Mixing
- Paper Dust

Metalworking

- Abrasive Cleaning
- Sandblasting
- Grinding/Polishing
- Laser Cutting
- Weld Fume
- Battery Manufacturing