



Better Air is Our Business®

AmericanAirFilter® Type N RotoClone® Hydrostatic Precipitator - Model LV

Installation, Operation and Maintenance Instructions

Table of Contents

1.0 Description	4.0 Maintenance Instructions
1.1 General Information	4.1 Removal of Collected Material
1.2 Operating Principle	4.2 Routine Maintenance
2.0 Installation Instructions	5.0 Troubleshooting
2.1 Foundations	5.1 Correction of Poor RotoClone Operation
2.2 Lubrication	
2.3 Duct Connection	6.0 LVN Bench Attachment
2.4 Water Supply Connection	6.1 Description
2.5 Drain Connection	6.2 Installation Instructions
2.6 Electrical Connections	6.3 Operating Instructions
2.7 Water Level Control	6.4 Maintenance Instructions
3.0 Operating Instructions	6.5 Troubleshooting
3.1 To Fill RotoClone	
3.2 To Start RotoClone	
3.3 To Stop RotoClone	

1.0 Description

1.1 General Information

The Type N RotoClone is a complete dust control unit. Designed to perform its various functions automatically, the RotoClone requires very little maintenance. Like any other mechanical equipment, however, it should have regular attention and be operated according to instructions to insure long life and trouble-free service.

1.2 Operating Principle

The Model LV RotoClone collector cleans the air by the combined action of centrifugal force and a violent inter-mixing of water and dust-laden air. The dust is separated from the gas stream by means of a water curtain created by the high velocity flow of air through a stationary impeller (see Figure 1). This high velocity flow carries water with it in a heavy turbulent sheet. The centrifugal force exerted by the rapid changes in direction of air flow causes the dust particles to penetrate the water droplets and become permanently trapped within them (Figure 1).

The dust-laden water droplets are then removed from the air stream by the water eliminator. The dust settles in the bottom of the collector and the water is reused. Since the water curtain is produced by the airflow, no pumps or nozzles are required.

2.0 Installation Instructions

Read the following instructions completely and carefully.

2.1 Foundations

Foundations must be true, level and rigid enough to prevent vibration and to support the weight of the RotoClone with its maximum dust and water load given below.

Size	Maximum Operating Wt. Lbs. (Note 1)	Normal Operating Wt. Lbs. (Note 2)	Water Capacity Gallons	Erecting Weight (Lbs.)
500	1,670	1,570	61	1,045
1,000	1,700	1,600	61	1,075
1,500	2,360	2,160	102	1,320
2,000	2,400	2,200	102	1,360

Note 1: Weight based on maximum sludge capacity with a sludge weight of 80 pounds per cubic foot.

Note 2: Weight based on weight of water 62.4 pounds per cubic foot.

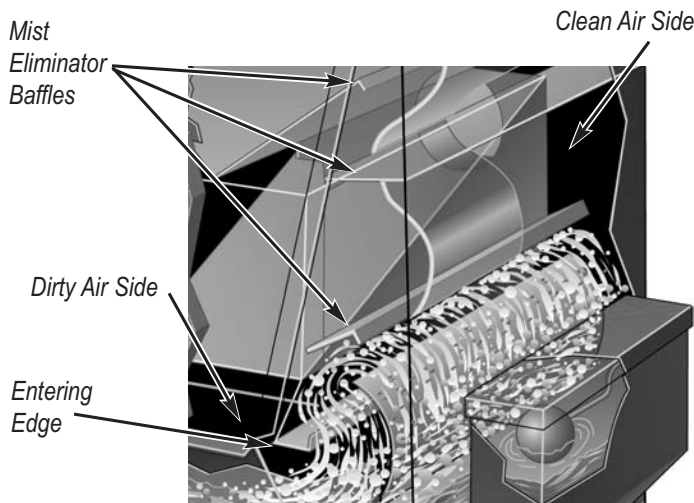

Figure 1
Cross section of Type N RotoClone Impeller.

Installation Instructions continued

Set RotoClone on foundation and adjust base until unit is level. Use care in leveling in both directions as functioning of RotoClone depends on accuracy of this operation.

Note: This level can be checked by filling the unit with water until the level reaches the entering edge (Figure 1) of the impeller. This entering edge should be level with the water along its entire length with maximum variation of $\pm 1/16$ " plus or minus. (See Item 1.2, Operating Principles)

2.2 Lubrication

All motor bearings are packed with grease before leaving the factory. Do not add more grease during installation. Some motors have lubrication plugs. They should be removed and replaced with grease fittings. Lubricate every six months under dusty operating conditions, and every 12 months under reasonably clean conditions.

2.3 Duct Connections

The inlet duct must be supported from the floor, wall or ceiling, not from the RotoClone. Four (4) to five (5) inlet diameters of straight duct, prior to the RotoClone, should be allowed to "balance out" uneven air/dust flow from elbows branch entries or other disturbances in front of the RotoClone.

2.4 Water Supply Connection

Units are supplied with a 1" (FPT) quick fill valve and $1/4$ " (FPT) solenoid valve for automatic water makeup. Connect supply piping to both.

2.5 Drain Connection

A 2" (FPT) drain valve is supplied at the bottom of the hopper. Drain piping, should be attached here and to the 1" (FPT) overflow coupling on the side of the sludge chute.

2.6 Electrical Connections

The normal electrical connections for the RotoClone are to the exhauster motor, water level control - solenoid valve, electronic probe (Model A control), the electrical control box (shipped loose), and the owner's motor starter (the motor starter, S/S push buttons, control transformer and disconnect are not normally supplied by AAF International). Each connection is to be made in accordance with the appropriate wiring schematic in the RotoClone instruction packet and prevailing electrical codes.

CAUTION:

1. Insure that motor voltage matches line voltage, and wiring is per diagram on motor.
2. After connecting the motor leads, insure that the motor rotates in a clockwise direction as viewed from the top of the unit.

2.7 Water Level Control

Supply water makeup for the RotoClone is required because of water losses due to evaporation and sludge removal. There are three types of water level control available on the Type N RotoClone Model LV.

- A. Manual control—Water is added through the sludge removal chute. Water level is controlled to the mark found on the level indicating tube.
- B. Float valve control—A float valve is mounted within a control box located on the side of the RotoClone. The float valve must be adjusted to control the water level to the mark on the level indicating tube. A pressure regulator is provided to improve level

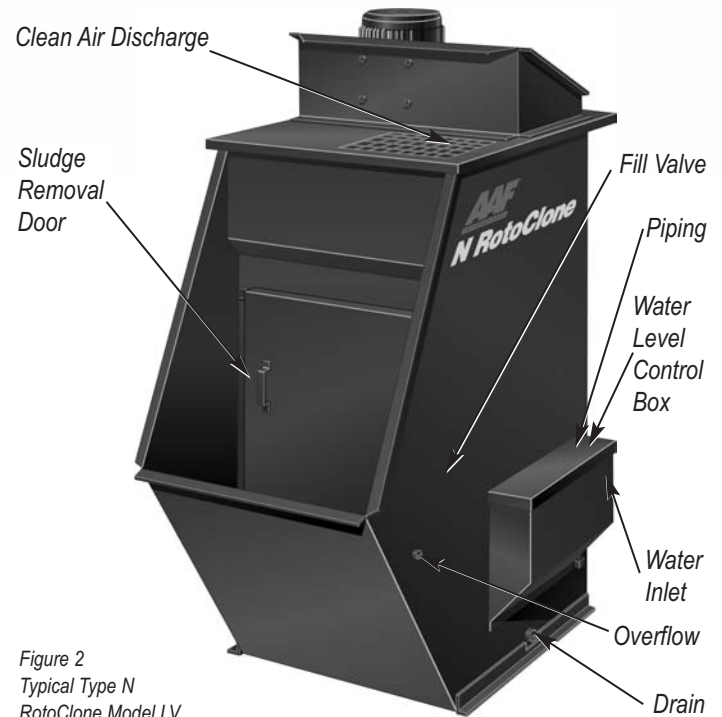

Figure 2
Typical Type N
RotoClone Model LV.

control. The regulator should be set at 5 psi. A solenoid valve is also provided. It is to be interlocked with the fan motor starter. The solenoid valve prevents overfilling during shut down. Controls also include a low water level switch and timer.

- C. Level probe control (Model A) – Includes an electronic level controller, level probe, solenoid valve and timer/relay to shut the unit down when water level in the RotoClone is too low. The water level controller and timer/relay are housed in a NEMA 4 control box, shipped separately. The water level controller actuates the solenoid valve when water level does not touch the electronic probe for more than 2 minutes (the time delay minimizes solenoid "chatter"), and allows the solenoid to close when water level again touches the probe. If water does not reach its proper level in the preset time (usually 3 minutes), the timer/relay shuts down the system.

3.0 Operating Instructions

3.1. To Fill RotoClone

- A. Close drain valve or insert drain plug (on older units without drain valve), and open any manual valves in the supply piping.
- B. Fill the RotoClone with water to approximately $1\frac{1}{2}$ " to 2" below the operating level on the level indicating tube. The unit will be marked with a horizontal line indicating "Air (Fan) On" water level. For units with the electronic probe, water level should be $1\frac{1}{2}$ " to 2" below the probe tip.

3.2 To Start RotoClone

- A. Check that the water level is approximately 2" below the operating level on the level indicating tube.
- B. Make sure sludge removal door is in place.
- C. Press "start" button for exhauster motor.
- D. Adjust water level to the correct operating level as shown on the level indicating tube, or until it just touches the electronic probe.

Operating Instructions continued

3.3 To Stop RotoClone

- A. Press exhauster motor "stop" button.
- B. Turn off water supply. Even on units supplied with solenoid valves, it is recommended that a manual valve be placed in the water supply line, prior to the RotoClone, for maintenance purposes and occasions where the RotoClone will be idle for extended periods of time.

4.0 Maintenance Instructions

4.1 Removal of Collected Material

In general, the Model LV RotoClone is best suited for light or moderate dust loadings such that the interval between each sludge removal is of a reasonable length. The required cleaning interval can be determined for any given RotoClone installation by using the rule shown below.

Cleanout interval established must be frequent enough to prevent collected material from exceeding a depth of 6" (2" for light metals).

The sludge depth may be checked by probing through the access door periodically during the first week of operation. At the end of the week, inspect the unit to determine the depth of sludge accumulation. Based upon this inspection, a fixed schedule should be established for regular sludge removal.

Note: RotoClone may be cleaned without draining.

A. To Drain RotoClone

1. Ideally, the RotoClone should be shut down for a few hours prior to draining to allow solids to settle.
2. Open the drain slowly such that flow increases gradually. This will prevent a sudden rush of solids into the drain. Initially, a small amount of the sludge layer will erode away in the vicinity of the drain. The clearer water will then flow out and tend to leave the remainder of the sludge layer intact.

If the drain is plugged, backflush the drain with a hose or manually back the sludge away from the drain in order to establish flow. Drain pluggage is an indication that the frequency of cleaning should be increased.

B. To Clean RotoClone

1. Collected material can be raked up sloping side thru main access door. Dust and metal chips can be easily removed with a 12" wide hoe.
2. Mud or sludge pumps are available from several manufacturers. They can be used to pump the settled material into a suitable container. Sometimes a "wet-vac" type unit can be utilized.

C. To Maintain RotoClone

During the draining and cleaning of the RotoClone, a routine inspection and cleaning of water level control box and float switch, electronic probes if supplied, and RotoClone housing, should be done.

D. To Fill RotoClone

RotoClone should be filled after removal of collected material. Follow instructions Item 3.1, Operating Instructions.

4.2 Routine Maintenance

To insure proper operation of the RotoClone, these procedures should be followed as a minimum. More frequent cleaning may be required for certain applications.

A. Water Level Control Box:

1. Observe water level in sight tube (electronic probe hose connection) frequently. Be certain that water level is at the running level. Verify that no blockage occurs in the connections of the tubing (or hose) to the RotoClone housing.
2. Clean water control box, sight tubing, and connection hosing as needed.
3. Wipe down electronic probe or float switch.

B. Water Eliminator:

1. Inspect each week and remove any accumulation. Cleaning methods will vary with material collected. Hosing is effective for many materials. Scraping or washing may be necessary.

C. RotoClone Housing:

After one month's operation, drain RotoClone and check for build-up on any surface. Check all impeller surfaces and hopper walls carefully and wash down with water hose, if required. Frequency of this operation can be extended until proper cycle for a given application has been determined.

D. Exhauster:

1. Periodically check exhauster for excessive vibration.
 - a. If vibration of the fan becomes excessive, the exhauster should be disassembled and thoroughly cleaned.
 - b. Inspect exhauster wheel by removing the top assembly. After top has been removed, motor and impeller can be easily serviced. Any accumulation of material should be removed.
2. Relubricate motor bearings every 12 months (more often if conditions require).
 - a. Stop the motor. Lock out the switch.
 - b. Thoroughly clean off and remove pipe plugs from bearing housing.
 - c. Remove hardened grease from drains with stiff wire or rod.
 - d. Add grease to inlet with hand gun until small amount of new grease is forced out the drain.

Grease. For best results, grease should be a good grade of petroleum oil. It should be of No. 2 consistency and stabilized against oxidation. Operating temperature range should be from -15°F to $+250^{\circ}\text{F}$ for Class B insulation, and to $+300^{\circ}\text{F}$ for Class "F" and "H". Most leading oil companies have special bearing greases that are satisfactory.

E. Replacement Parts:

Parts of the RotoClone will not require frequent replacement and spare part stock is seldom necessary.

When ordering any parts, give RotoClone size, type and serial number.

5.0 Troubleshooting

5.1 Correction of Poor RotoClone Operation

Most difficulties that may be encountered in RotoClone operation will be discovered and corrected by one or more of the following:

AmericanAirFilter®

Type N RotoClone®, Model LV

Maintenance Instructions continued

- A. Reduction in air flow at exhaust hoods:
1. Reduced exhauster flow due to pluggage.
 2. Accumulations in ducts or hoods due to sticky nature of dust or settling in ducts caused by low conveying velocities.
 3. Addition of more exhaust points to the system.
 4. High water level in RotoClone. This can be observed at the level indicating tube.
 5. Pluggage at the eliminator shelves or accumulations in impellers or dirty air chamber.
 6. Fan running backwards.
- B. Reduced dust collection efficiency can be caused by:
1. Extreme reduction in air flow.
 2. Low water level in RotoClone.
 3. The unit out of level.
 4. Corrosion or abrasion to impeller sections.
 5. Material buildup inside collector.
- C. Water entrainment in Exhauster Discharge:
1. Build up of water in the fan plenum. There is a drain hole near the front of the fan discharge.
 2. Excessive air flow through RotoClone. To stop entrainment caused by excessive air flow, increase static pressure by partially closing the outlet slide damper located on top of the RotoClone.
 3. Surging of the RotoClone is a rocking of the water from end to end in the unit. This can be caused by running the unit well below its rated capacity or too high an external pressure resistance. Contact your local AAF sales representative for assistance.
 4. Material buildup on mist eliminator baffles.

6.0 LV Bench

6.1 Description

The Model LV Collector Downdraft Bench Unit is a self contained work station designed to provide the convenience of an industrial work table and efficiency of a built-in dust collector.

The large FRP grating surface and shallow capture plenum form a dust free work surface suitable for standing or sitting with plenty of knee and leg room.



6.2 Installation Instructions

The bench portion of the LVN bench ships separately for field assembly and bolts to the LVN (see drwg. 1490812). Use Butyl caulking in the transition joints. Side and back panels are standard. A concrete floor that can support the LVN can support the N bench. The 500 and 1000 size bench is 30 x 28 and the 1500 and 2000 size bench is 30 x 56. The operating weight of the smaller unit will be approximately 300 lb. and the larger unit will be approximately 600 lb. The water for the bench is supplied from the LVN, and the water level control (in the LVN) will make up for evaporation.

6.3 Operating Instructions

- A. Filling
Fill the RotoClone with water as described in Section 3.1 of the standard LVN RotoClone operating instructions.
- B. Starting
Start the RotoClone fan motor. The fan motor is three phase and needs to be checked for rotation. Rotation is clockwise looking from the top.
- C. Checkout
Check amps on motor and adjust slide damper on fan discharge if fan exceeds full load amps. Should you have water droplets in the fan discharge, you may find that the air volume is exceeding the rating of your unit. Closing back on the damper should solve this carryover problem.

6.4 Maintenance Instructions

- A. Removal of Collected Material
Any material collected on the flat surfaces of the bench, as well as material collected in the RotoClone, should be removed at regular intervals. See previous maintenance section for removal suggestions.

6.5 Troubleshooting

- A. Reduction in downflow velocity
1. Reduced exhauster flow due to pluggage.
 2. Accumulation in the dirty air ducts.
 3. Water level in the LVN RotoClone too high.
 4. Fan running backwards.
 5. Pluggage in the RotoClone.
 6. Reduction in airflow (See Section 5.1-A).
- B. Reduction of dust collection efficiency
1. Low water level in the LVN RotoClone.
 2. Unit not level.
 3. Corrosion or abrasion to impeller or mist eliminator baffles.
 4. Reduction in airflow. (See Section 5.1-A).



Better Air is Our Business®

10300 Ormsby Park Place Suite 600
Louisville, Kentucky 40223-6169
www.aafintl.com

Customer Service 800.477.1214
Fax 800.254.3019

ISO Certified 9001:2000

AAF has a policy of continuous product research and improvement and reserves the right to change design and specifications without notice.

©2008 AAF International
APC-3-519B MAR '08 QG 500