



Better Air is Our Business®



AmericanAirFilter® Explosion Venting and Brixon Latch

Adjustment Instructions

Table of Contents

- 1.0 Description
- 2.0 Release Pressure
- 3.0 Latch Adjustment
- 4.0 Maintenance
- 5.0 Venting
- 6.0 Latch Technical Data
- 7.0 Explosion Vent Technical Data

1.0 Description

Explosion vents on dust collectors manufactured by American Air Filter are intended to open quickly and relieve the sudden rise in pressure build-up from deflagration (burning which takes place at a flame speed less than the velocity of sound). Vents do not prevent the occurrence of a deflagration but are intended to limit the damage from the pressure rise generated by a deflagration.

Explosion vents do NOT provide protection from detonation (burning which takes place at a flame speed greater than the velocity of sound). This exceeds generally recognized industrial standards or safety practices and is beyond the scope of this equipment. Fortunately, few industrial dusts burn by detonation. Most burn by deflagration.

Since explosion vents must open quickly to provide rapid pressure release, they must be tested regularly to insure that they operate satisfactorily. See **Maintenance**.

When it is not practical to locate dust collectors of hazardous dust outdoors, vent duct should be used. See **Venting** and also see National Fire Code Guide for Explosion Venting (NFPA-68).

The size and number of explosion vents used is usually pre-determined by American Air Filter, based on NFPA-68 recommendations for St-2 Class dust and dust collector size. Technical data used for selecting the vents, as well as for the latches used on the vents, is shown on charts 1 and 2 on the back page. These explosion vents are factory installed but do require on-site adjustment of "RELEASE PRESSURE" to suit operating conditions.

2.0 Release Pressure

The pressure at which explosion vents should be set to open (Release Pressure) is obtained by turning the latch adjustment screw. See **Latch Adjustment**. Latch adjustment is made to provide the lowest practical setting for the explosion vent to open, without interfering with normal operation of the dust collector. The explosion vent should not be opened by normal fan pressure nor from shaking or pulsing during cleaning. Occasionally, nuisance openings may occur from unusual causes (such as negative wind pressure), in which case, a slightly higher setting may be used if the occurrence is frequent and annoying.

Explosion vents can be furnished for either negative or positive pressure applications.

Negative Pressure Vents have the fan located downstream from the dust collector, and the vent is normally under suction pressure which helps to hold the vent closed. For these vents, the smallest latch; Model No. 91, is used.

Positive Pressure Vents have the fan located upstream from the dust collector, and the vent is normally under positive fan pressure, which adds to the pressure necessary to hold the vent closed. For these vents, the larger and stronger latch, Model No. 3, is used.

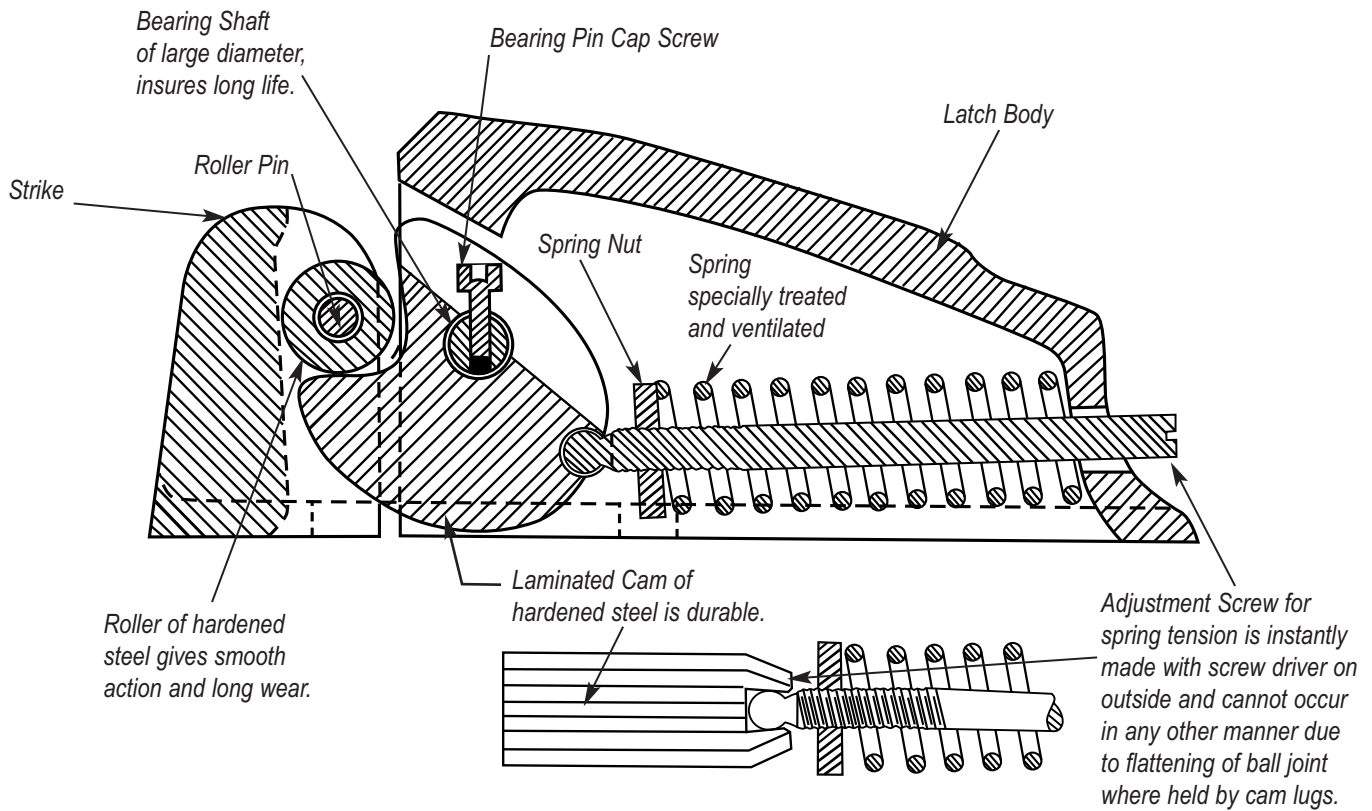

Brixon Latch Adjustment

3.0 Latch Adjustment

The proper minimum setting for the latch adjustment and resulting vent release pressure is best determined on-site after the dust collector has been placed in service.

The ArrestAll AR Series is cleaned by shaking the cartridge with the fan off. With the integral fan atop the dust collector, the explosion vent is always for use on negative pressure. Model No. 91 latches are therefore always used and they should be factory set for near minimum release pressure, with just enough latch release force to prevent nuisance openings.

To reset, switch the fan **OFF**, and turn the latch adjusting screws counter clockwise as far as they will go. Then test the setting by turning on the shaker. If the explosion vent is jarred open by the shaking action, turn the adjusting screws clockwise one turn and

test again by shaking. Repeat this procedure until the vent remains closed and does not suffer nuisance openings.

Design M FabriPulse and Millennium collectors are cleaned by pulsing with high pressure air while the fan is running. Therefore, these latches must be field adjusted for release pressure as follows:

To set, turn on the fan and the pulse cleaning system, and wait for the pulse pressure to challenge the latch settings. If the explosion vent does **NOT** open, loosen (counter clockwise) the latch setting by one turn and wait for the pulse pressure to challenge the vent again. Continue loosening the latch setting by one turn at a time until the vent **DOES** open from the pulse pressure. Then retighten the latch by one-half turn and test again. Continue tightening the latch adjusting screws one-half turn at a time until the vent remains closed during pulsing and does not suffer nuisance openings.

4.0 Maintenance

Explosion Vents must be tested regularly to insure that they operate satisfactorily. The latches must be kept free of foreign material which could affect the mechanism. Foreign material, ice crystals, and paint may produce a cementing action on the vent allowing greater pressure to build up before the vent will open. A coating of grease on the adjacent surfaces may prevent the bridging of ice crystals between the members of a vent. Corrosion and paint may also increase friction in opening a vent.

Brixon Latches for use on AAF Explosion Vent applications are made of materials which are generally resistant to exterior environment provided they are inspected and lubricated at frequent and regular intervals. Lubricating should be as follows: Apply heavy grease to the spring and laminated cam inside latch upon original installation and re-grease as necessary every 6-12 months. The crucial pivot joint, which is the bearing pin about which the laminated cam pivots, should be oiled with an SAE 30 to SAE 50 oil every two months or more in case of an extremely corrosive atmosphere.

Inspection should be done at least every 2 months:

1. Check to see that latch is adequately lubricated.
2. Open vent (collector not operating) to make sure all parts are free to move. Move vent through full arc of travel two or three times, latching vent each time.
3. Inspect Explosion Vent hinges and lubricate with SAE 30 to SAE 50 oil as required.
4. Inspect door gasket and replace when necessary.
5. Upon final closure, make sure the Brixon Latch secures the vent in closed position properly.

REMEMBER:

Your Explosion Vent cannot protect your equipment properly if the Brixon Latches and vent hinges are not free to function at all times.

WARNING:

Explosion Vents should be approached with extreme caution. In case of dust ignition or internal explosion, sudden increase in pressure will cause the Explosion Vent to open rapidly. When this occurs, injury or death could result from contact with hinged vent or with ensuing flames which may burst forth in all directions for a considerable distance.

5.0 Venting

Where possible, dust collectors for hazardous dust should be located outdoors. When indoor location is unavoidable, the dust collector must be placed as near as possible to an outside wall. Vent ducts should be used to direct the explosion to a safe location outside to avoid injury to personnel and minimize property damage.

Vent duct layout must allow for frequent access to explosion vents for inspection, testing, and lubrication. The dust collector explosion vents do **NOT** contain allowances for venting the duct.

Vent ducts should not be obstructed and should be constructed to withstand the maximum pressure of deflagration. Duct length should be minimal and bends should be avoided. It should be realized that any duct will decrease the effectiveness of the vent in proportion to the duct length. For more information, see National Fire Codes, Guide for Explosion Venting.

Explosion Venting and Brixon Latch

6.0 Latch Technical Data

Latch Model No.	Latch Release Force – Lbs.		Force Change Per Turn Lbs.	Force Change Per Half Turn Lbs	Full Turns Available
	Min.	Max.			
91	3.9	17	1.46	0.73	9
3	43	180	5.96	2.98	23

7.0 Explosion Vent Technical Data

Product Use	Vent Size, Inches	Vent Area, FT ²	Type Pressure	Latches Per Door & Model No.	Min. Vent Opening Force/ Pressure With Min. Latch Setting	
					Pounds Total	Static Pressure In w.g.
ArrestAll, AR Series	12 x 18	1.5	Neg.	2 - #91	15.6	2.0
	18 x 16	2	Neg.	2 - #91	15.6	1.5
Millennium	24 x 24	4	Neg.	3 - #91	23.4	1.1
			Pos.	3 - #3	258	12.4
Design M FabriPulse	24 x 36	6	Neg.	4 - #91	31.2	1.0
			Pos.	4 - #3	344	11.0
FabriPulse Model B or C	29 ¹ / ₂ x 29 ¹ / ₂	6	Neg.	3 - #91	23.4	0.8
			Pos.	4 - #3	344	11.0



Better Air is Our Business®

10300 Ormsby Park Place Suite 600
Louisville, Kentucky 40223-6169
www.aafintl.com

Customer Service 800.477.1214
Fax 1.800.254.3019

ISO Certified 9001:2000

AAF has a policy of continuous product research and improvement and reserves the right to change design and specifications without notice.

©2007 AAF International
APC-3-450 AUG '07