



Better Air is Our Business®

AmericanAirFilter® Universal Holding Frames & Latches

***Gasketed, Modular Filter Holding
Frames and Latches***

Universal Holding Frames

AAF Universal Holding Frames come in seven standard sizes that can be used individually or may be combined to fit virtually any size filter bank. Each frame includes a gasket to ensure a proper seal between the frame and filter to minimize dirty air bypass. Also included are AAF's unique holding latches designed to hold the filter in place and create a positive seal. The latches are easy to use, requiring only a simple twisting motion to release the filter.

Universal Holding Frames are constructed of galvanized steel. The frames are available in 304 stainless steel, and there is an aluminized steel version for high temperature applications. (Note: 304 stainless and aluminized steel frames are slightly different in appearance but are of the same high quality and durability as the galvanized steel models.) All frames feature holes on each side for bolting or riveting into filter banks.

Seven sizes are available: 24 x 24, 20 x 25, 20 x 20, 16 x 25, 16 x 20, 20 x 24, and 12 x 24. The 2¹³/₁₆" deep frame will support all standard combinations of pre and final filters.

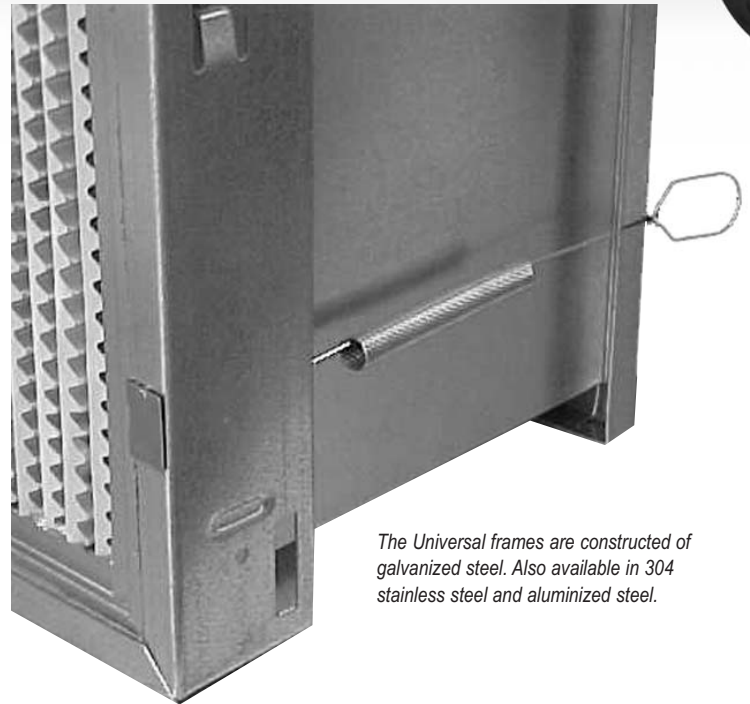

The Universal frames are constructed of galvanized steel. Also available in 304 stainless steel and aluminized steel.

High Temperature Applications

Filtration systems for paint curing ovens and other high temperature applications can be served using an aluminized steel Holding Frame constructed without a gasket. The aluminized steel frame will tolerate temperatures up to 900°F. The standard gasket is good for temperatures up to 140°F.

Filter Latches

AAF latches are available to hold a variety of filters and filter combinations, are replaceable, and specifically designed for upstream or downstream servicing. Each latch is annealed to music wire specifications after forming, and commercially zinc plated to provide years of service under varying environmental conditions. The Universal Holding Frame sides feature a unique retaining tab to hold the "L" Series latches. "L" Series latches do not connect to, or disturb, the flat sealing flange and gasket surface.

The L-42 and L-44 latches, specifically designed for the VariCel® II filter in combination with prefilter, offer an additional advantage. The latch can be turned to release the prefilter while maintaining a pressure seal on the higher efficiency VariCel II filter.













Conversion Latches

AAF sells "Knock On" latches to allow installation of all combinations of AAF filters in other manufacturers' filter holding frames.

AmericanAirFilter®

Universal Holding Frames & Latches

Universal Frame Latch Selection

Final Filter	Pre-filter	Service	Latch (Four latches recommended per frame.)
1" Nominal or Header Filters DriPak® VariCel® VariCel® V BioCel® 5700™ AmerFrame®	None	Upstream or Downstream	L-10 
	2"	Upstream	L-30 
	4"	Upstream	L-50 
2" Nominal Filters AmAir® 5700™ RenuFrame™ AmerFrame®	None	Upstream or Downstream	L-20 
	2"	Upstream	L-40 
	4"	Upstream	L-44 
4" Nominal Filters VariCel® II AmAir®	None	Upstream or Downstream	L-40 
	2"	Upstream	L-42 
	4"	Upstream	L-44 
12" Nominal Filters DH VariCel® DH BioCel®	None	Upstream or Downstream	SL-12 
	2"	Upstream	SL-12 VP-2 
	4"	Upstream	SL-12 VP-4 

Specifications

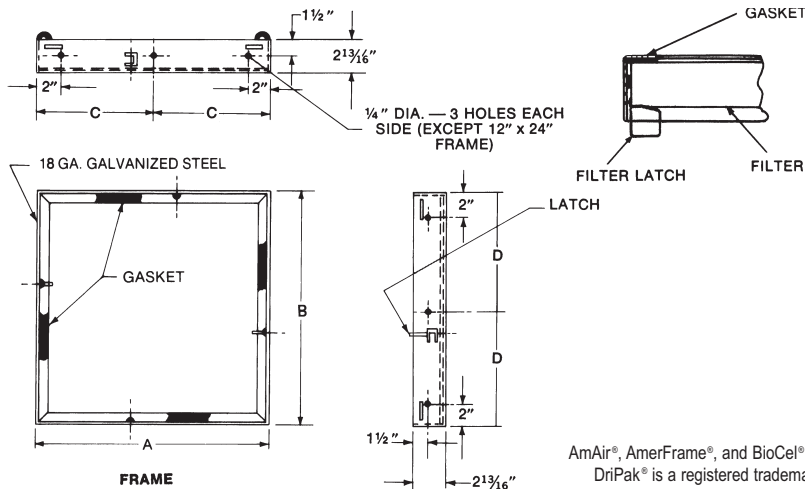

A	B	C	D
20"	20"	10"	10"
20"	25"	10"	12 1/2"
16"	20"	8"	10"
16"	25"	8"	12 1/2"
24"	24"	12"	12"
12"	24"	—	12"
20"	24"	10"	12"

AmAir®, AmerFrame®, and BioCel® are registered trademarks of AAF-McQuay in the U.S. DriPak® is a registered trademark of AAF-McQuay in the U.S., Brazil, and Venezuela.

AAF INTERNATIONAL
 10300 Ormsby Park Place Suite 600
 Louisville, Kentucky 40223-6169
 www.aafintl.com
 Customer Service 888.AAF.2003
 Fax 888.223.6500



AAF has a policy of continuous product research and improvement and reserves the right to change design and specifications without notice.

ISO Certified Firm

©2010 AAF International
 The USGBC Member logo is a trademark owned by the U.S. Green Building Council and is used by permission.