

# AmericanAirFilter<sup>®</sup> ArrestAll<sup>®</sup> Model AR

## Self-Contained Dust Collector

### Installation, Operation, and Maintenance Instructions



#### Table of Contents

##### 1.0 General

- 1.1 Shipment
- 1.2 Foundations
- 1.3 Space Requirements
- 1.4 Handling

##### 2.0 Installation

- 2.1 Anchoring
- 2.2 Field Assembly of Major Components

##### 3.0 Electrical Installation

##### 4.0 Accessories

- 4.1 Inlet Transitions—Flat Bottom Units
- 4.2 Explosion Vent
- 4.3 Drums
- 4.4 Final Filter

##### 5.0 Operation

##### 6.0 Maintenance

- 6.1 Fan and Motor Replacement
- 6.2 Lubrication
- 6.3 Filter Cartridge Change-out

##### 7.0 Troubleshooting

- 7.1 Visible Discharge
- 7.2 Insufficient Suction or Exhaust
- 7.3 Cartridge Problems (Blinding, Poor Life, Failure, etc.)
- 7.4 Electrical

##### 8.0 Shipping Information

##### 9.0 Replacement Parts

#### 1.0 General

The AR ArrestAll<sup>®</sup> self-contained dust collector is a compact and efficient unit designed to control intermittent, low to medium volume, dry, dust sources. It is cleaned off-line. The unit includes an air mover and can be relocated as required.

Each collector is furnished with fan assembly, housing, filter cartridge(s), and automatic shaker mechanism for filter cleaning. Based on size, they are available as a bin vent, flat bottom, cart bottom, and funnel bottom arrangements. The size range is from 1,000 to 12,000 ACFM. Read the entire brochure and check each carton and crate against the shipping sheet (AAF Form 1281) before beginning assembly work. **DO NOT** store the AR ArrestAll dust collector outdoors.

#### 1.1 Shipment

The AR ArrestAll collector is packaged for domestic transit and shipped FOB factory. Notify your carrier immediately if there is any damage or discrepancy in the shipping papers.

The AR ArrestAll funnel bottom units are shipped as three major components: the fan, the funnel bottom section, and the cartridge housing section. The bin vent, cart bottom, and the dust drawer units ship as two major components: the fan and the complete housing assembly. See "Installation Drawing" for proper field assembly.

### 1.2 Foundations

The foundation must be level and adequate to support the collector's operating weight including dust load, discharge devices, wind load if applicable, plus any auxiliary equipment if applicable.

### 1.3 Space Requirements

Unit location will be determined by system design, space availability, and access requirements. Access to the front of the unit is necessary for dust removal and cartridge replacement. Top access is required for motor, fan, and ancillary component service. Side access is required for shaker motor and control access.

Explosion vents, if furnished, are located on the side opposite the access door. It is recommended that the vent(s) be ducted outside and away from any area containing personnel or equipment. Duct flanges can be match drilled to the collector housing wall, but they must be supported separately from the unit.

### 1.4 Handling

All units are shipped in an upright position. Lifting lugs are provided on the cartridge section as well as the fan for ease of handling (Figure 1). Spreader bars should be used on the housing. Fork truck handling should be sufficient for the funnel section. Shipping weights are listed in the table in Section 8.0.

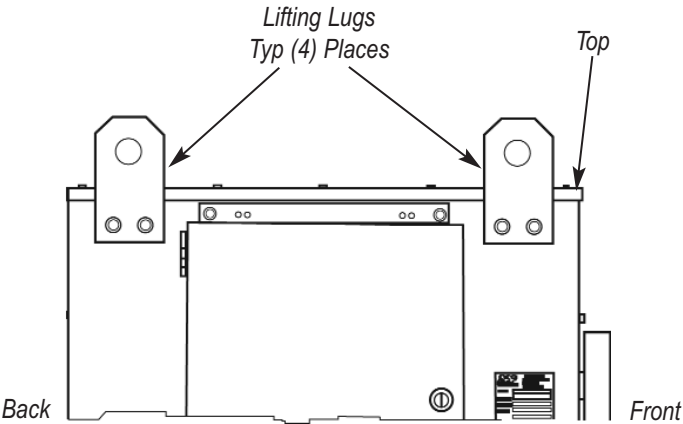

Figure 1. Lifting Lugs

### 2.0 Installation

The AR ArrestAll dust collector is not designed to support inlet and/or outlet ductwork. The duct(s) should be connected to the collector with flexible connections to eliminate vibration transmission.

Close coupling a duct elbow to the collector inlet may result in an uneven velocity profile. This condition could cause previously collected material to be re-entrained. Three to four duct diameters of straight run will give an even airflow distribution at the inlet.

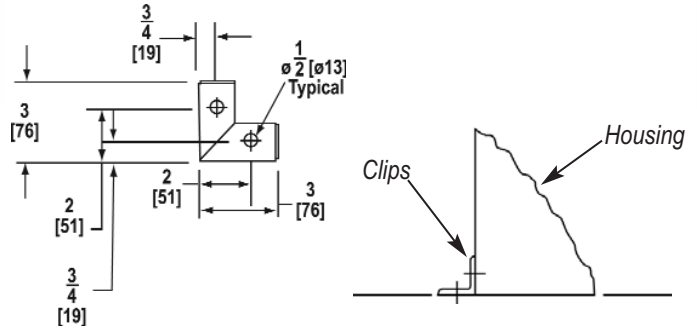

Figure 2. Anchoring—Funnel Bottom

Figure 3. Anchoring—Cart Bottom

### 2.1 Anchoring

The AR ArrestAll collector is designed for installation on a flat surface. **Units must be suitably anchored.** Anchor holes are provided at the base of the support legs on the funnel bottom units (Figure 2), and anchor clips are provided on the cart bottom (Figure 3). Flat bottom units can be installed by drilling holes in the bottom of the units. Holes drilled in the flat bottom base should be gasketed or caulked to prevent air bypass.

### Inlet Transitions

Standard accessories, such as the inlet transition (AR1 only), are shipped loose for field installation with the caulk and attachment hardware provided.

### 2.2 Field Assembly of Major Components

#### Funnel Bottom Units

Self-tapping screws and caulk are provided for installation of the funnel bottom section to the cartridge section (Figure 4). Assemblies can be bolted-up from the outside of the unit; interior access is not required. See the field installation drawing for additional detail. The fan is bolted to the top of the unit using the provided hardware. Fan discharge orientation can be varied to suit owner's requirements. See the fan installation drawing for additional detail.

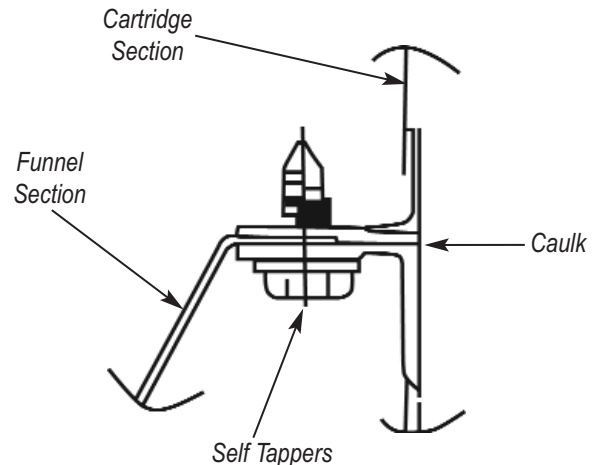

Figure 4.

### Flat and Cart Bottom Units

These units are fully assembled at the factory except for the fan. Fan discharge orientation can be varied to suit owner's requirements. See the fan installation drawing for additional detail.

### Bin Vent Units

To prevent possible damage to the unit from ponding water, it is recommended that curbing be used on any bin vent installation (Figure 5).

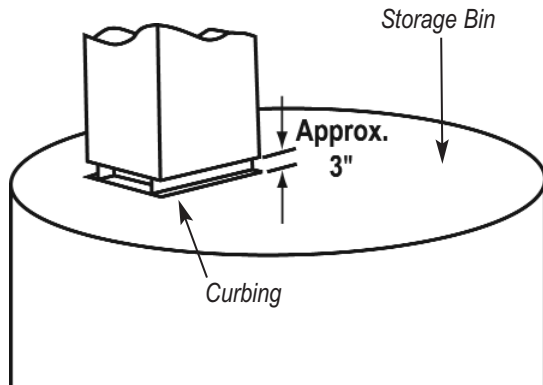

Figure 5. Bin Vent

### Barrel Top Adapters and Slide Gates

Funnel bottom units come standard with a barrel top adapter. The barrel top adapters are field installed on the bottom of the funnel bottom (Figure 6). Slide gates are optional and are shipped loose for field installation.

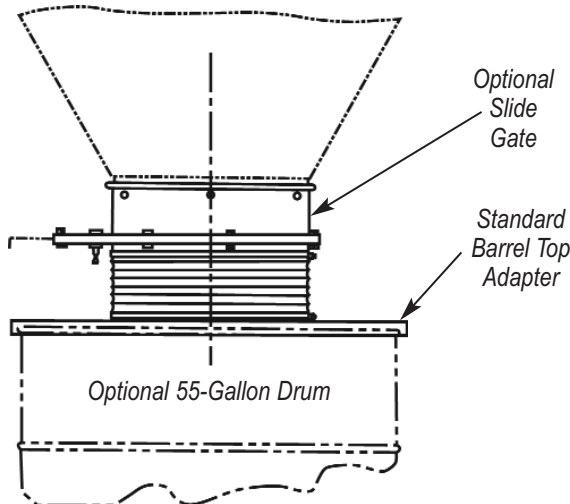

Figure 6. BTA - Slide Gate Installation

## 3. Electrical Installation

All wiring should comply with NEC and applicable local codes.

Refer to the fan installation kit assembly drawing number 3029105 and the wiring diagram furnished with the equipment for proper wiring of the control panel. The major electrical components are the fan motor and automatic shaker motor and control. Factory wiring is standard on all units with the only exception being the fan motor. Use the wiring kit provided to make the final electrical connection on the unit. See the fan installation drawing for additional detail.

The control should be connected to the power source through a fused disconnect. Check the fan rotation against the rotation arrow for correct motor connections. **Fan rotation should always be clockwise when looking down from the top of the motor.**

If incorrect, change the motor leads as indicated on the motor wiring instructions. Provide adequate grounding of the unit.

## 4. Accessories

### 4.1 Inlet Transitions - Flat Bottom Units

An inlet transition is furnished with the flat bottom unit. This rectangular to round duct section is shipped loose for field installation using the provided hardware and caulk.

### 4.2 Explosion Vent

The optional explosion vents are factory installed. A guard to contain and prevent damage from a rapidly opening vent is also provided as a separate item for field installation (Figure 7). Explosion vents should be installed in accordance with local, national, and all other applicable codes.

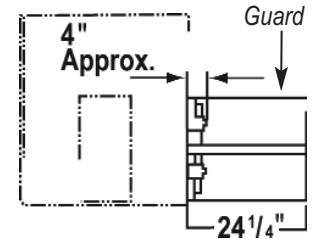

Figure 7. Explosion Vent Guard

### 4.3 Drums

55-gallon drums, when ordered, are shipped separately.

### 4.4 Final Filter

The final or secondary filter option consists of a filter enclosure with sealing mechanism and the final filter cartridge. The filter enclosure is shipped installed over the dust cartridge section. The final filters are shipped separately for field installation. Refer to the installation drawing for additional information.

## 5.0 Operation

The primary function of the AR ArrestAll dust collector is to move air, and thus create suction and remove the dust from the air. As a dust cake develops on the fabric surface of the filter, pressure drop will rise and airflow will be reduced. The unit must be shaken with sufficient frequency to preclude significant loss of suction.

Frequency of the dust removal from the bin should be determined from experience and an appropriate maintenance cycle established. Because of the intensity of shaking, it is imperative that the door be properly latched to prevent leakage.

With the hand-off-auto switch, the frequency of shaking can be controlled by the owner. It is recommended that shaking be minimized to extend the life of the filter cartridge and mechanical components. This is especially pertinent to installations where the unit might be turned on and off numerous times during the day, such as a school woodworking shop. In the "AUTO" position, the unit shakes every time the unit is turned off. In the "OFF" position, shaking can be actuated anytime the switch is pushed toward the "HAND" position. The fan must always be turned off before shaking.

The duration of the shaking process is adjustable from 0.6 to 60 seconds (recommended time set at approximately 15-20 seconds) with an initial fan coast delay which is adjustable from 0.6 to 20 seconds (recommended time factory set at 20 seconds).

For cold weather applications, it is especially important to allow the collector to operate for an extended period of time before shaking.

## 6.0 Maintenance

### 6.1 Fan and Motor Replacement

Fan and/or motor replacement requires removal of the fan from the top plate. Lock out electrical power to the motor. Remove the mounting bolts and lift the fan assembly away. By removing the appropriate bolts, the fan wheel can be removed and replaced. The fan wheel must be removed for motor replacement. A wheel puller may be required for replacement of the fan wheel.

#### Shaker Motor Replacement

Steps: (Figure 8)

1. Remove motor terminal cover and disconnect wires. Remove cable connector and wires from the motor.
2. Loosen bearing locking collar as follows:
  - a. Loosen set screw.
  - b. Rotate bearing so that the hole without the set screw faces you. Place a punch in hole and sharply tap punch in a CCW direction. If collar doesn't loosen, sharply tap in a CW direction to loosen. (Repeat if necessary.)

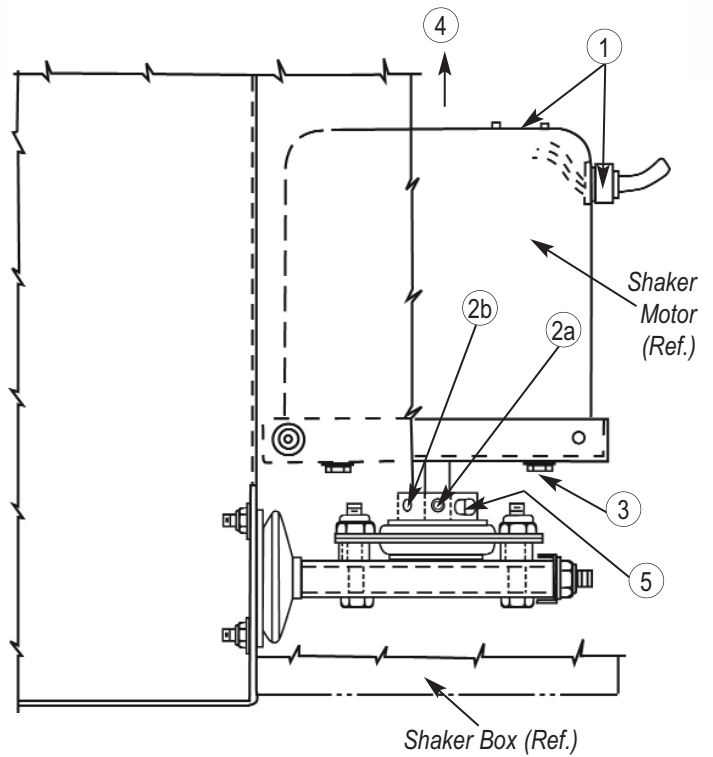

Figure 8. Shaker Motor Replacement

3. Loosen and remove motor mounting bolts.
4. Lift and remove motor. Eccentric (on motor shaft) should disengage from bore of bearing. Bearing will remain in flanges.
5. Remove eccentric from shaft by loosening two (2) set screws.

To reinstall, reverse above procedure.

Note: Install motor with electrical terminals accessible.

After reinstalling all parts, rotate bearings several turns by hand to insure equally free movement throughout rotation.

### 6.2 Lubrication

Follow the motor manufacturer's recommendations for lubrication procedures for the fan and shaker motor.

### 6.3 Filter Cartridge Change-Out (Figure 9)

1. Open cartridge access door. (Door may be lifted off for easier access).
2. Loosen the shaker comb adjustment bolt and pry apart the shaker comb locking channel (Picture 1).
3. Release the cartridge locking levers (2 per cartridge) by pushing each toward the center of the unit (Picture 2).
4. Remove the complete cartridge assembly from the unit (Picture 3).
5. Inspect gasket on septum for damage. It is recommended that the gasket be replaced whenever new cartridges are installed. Glue the gasket to the underside of the septum around the edges of the opening. The gasket splice should be located to the front of the unit.
6. Remove the shaker comb, retainer, and insert assemblies from the old cartridge assembly. Inspect for damage. **Do not throw these items away.** You will need them to assemble the new cartridge.

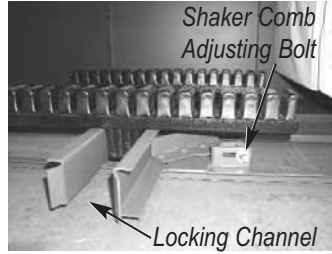

Picture 1



Picture 2



Picture 3

7. Remove the old pocket assembly from the frame assembly. Discard the old pocket assembly.
8. Assemble the new cartridge as shown in Figure 9 using the existing frame and pocket inserts.
9. Assemble the shaker comb to the bottom center of the cartridge assembly. Make sure each pocket with insert is set into the shaker comb finger (Pictures 4 & 5).
10. After the pockets are set into the shaker comb, install the retainer on top of the inserts (Picture 6).
11. Install the cartridge assembly into the ArrestAll by reversing steps 1 through 4.



Picture 4



Picture 5



Picture 6

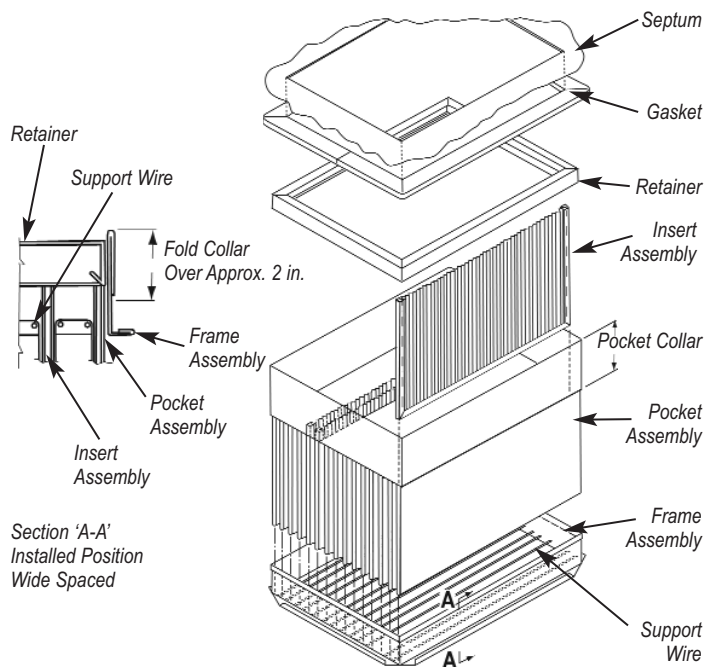

Figure 9. Cartridge Installation

## 7.0 Troubleshooting

### 7.1 Visible Discharge

#### Improperly Installed Cartridge

Insure the cartridge is properly locked and sealed in position. Check for worn or torn pockets and replace cartridge if required. Check for possible damage to the cartridge sealing gasket.

### 7.2 Insufficient Suction or Exhaust

#### High Pressure Drop

See cartridge problems.

#### Fan Direction of Rotation

The incorrect fan rotation will not provide sufficient static pressure or volume and could cause motor overload.

#### Leaks

Infiltration of air from leaking ductwork, access doors, explosion vents, dust discharge devices, or housing will cause insufficient suction. Seal any leaks.

#### Closed Air Passages

Clogged ducts or closed dampers or gates will shut off or reduce the airflow.

#### Undersized Ducts

Duct size should be per the design specification. Undersized ducts produce high static pressure, restricting the airflow.

#### Improper Shaker Cycle

Check the electrical components of the automatic shaker for correct operation. Adjust shake time if required (normally 15-20 seconds). Check for mechanical restrictions, which could hinder the performance of the shaker.

### 7.3 Cartridge Problems (Blinding, Poor Life, Failure, etc.)

#### Checks and Remedies

1. Check actual operating temperature of system against design temperature.
2. Check for high operating humidity, free moisture, etc. Check for low relative humidity and static electricity.
3. Check for shrinkage or stretching.
4. Review physical and chemical characteristics of collected dust, gas stream, and fabric.
5. Check for material bridging in bin. Material build-up into cartridge area can overstress the element.
6. Incorrect cartridge installation can cause wear by allowing friction between adjacent elements or between outside elements. Adjust as required.
7. Check for system design changes in air volume, dust loadings, etc. Adjust as required.

### 7.4 Electrical

#### Shaker Motor Does Not Operate

Verify that the shaker motor is operable. If it is, make the following electrical checks.

1. Confirm that the selector switch (SS) is in "HAND" or "AUTO" position.
2. Verify line voltage at Terminals 1L1, 1L2, and 1L3 and control voltage (115 volts) from control transformer.
3. Check that shaker overload 2OL is not tripped.
4. Check that shaker motor fuses F4, F5, and F6 are not blown.
5. If selector switch 'SS' is in the "AUTO" position, verify that fan starter (1M) Aux N.C. contact is closed and there is power at terminal 4. If selector switch 'SS' is in the "HAND" position, check for power at terminal 4.
6. If all of the above steps check out okay, the next check is for a faulty shaker timer (SSTM). A faulty shaker timer (SSTM) may be determined by disconnecting wire numbers '4', '7', and 'N' from the timer. Place a jumper between wire numbers '7' and 'N'. If shaker motor energizes, shaker timer (SSTM) should be replaced.

#### Notes:

1. Weights listed do not include crating and/or packaging.
2. Cartridge ships installed.
3. After-filter weight excludes filter.
4. After-filter ships separately in cardboard carton.
5. Inlet transition (if supplied) ships separately.

## 8.0 Shipping Information

AR SIZE	1-3	2-5	2-7.5	2-10	3-10	3-15
Number of Dust Discharge Outlets	1	2	2	2	2	2
Number of Cartridges	1	2	2	2	3	3
<b>WEIGHT IN POUNDS</b>						
Funnel Bottom	615	935	990	1000	1250	1430
Bin Vent	465	680	735	745	800	980
Dust Drawer	550	N / A	N / A	N / A	N / A	N / A
Dust Cart	660	1020	1070	1080	1300	1480
<b>OPTIONS</b>						
55-Gallon Drum(s) - 45 lb. Each	45	90	90	90	90	90
Weather Hood - for Silencer Only	13	13	13	13	13	13
Weather Hood - for Fan Only	10	12	13	15	15	16
Final Filter - Housing Only	155	250	250	250	380	380
VariCel® Final Filters - (1) Set	20	40	40	40	60	60
HEPA Final Filters - (1) Set	37	74	74	74	111	111
Explosion Vent(s) - 45 lb. Each	45	45	90	90	135	135

AR SIZE	4-10	4-15L	4-15H	4-20	6-20	6-25
Number of Dust Discharge Outlets	4	4	4	4	4	4
Number of Cartridges	4	4	4	4	6	6
<b>WEIGHT IN POUNDS</b>						
Funnel Bottom	1400	1500	1500	1530	1960	2070
Bin Vent	1030	1130	1030	1150	1443	1550
Dust Drawer	N / A	N / A	N / A	N / A	N / A	N / A
Dust Cart	N / A	N / A	N / A	N / A	N / A	N / A
<b>OPTIONS</b>						
55-Gallon Drum(s) - 45 lb. Each	180	180	180	180	180	180
Weather Hood - for Silencer Only	13	13	13	24	24	24
Weather Hood - for Fan Only	15	16	18	18	18	21
Final Filter - Housing Only	420	420	420	420	590	590
VariCel® Final Filters - (1) Set	80	80	80	80	120	120
HEPA Final Filters - (1) Set	148	148	148	148	222	222
Explosion Vent(s) - 45 lb. Each	90	90	90	90	135	135

# AmericanAirFilter®

## ArrestAll® Model AR

### 9.0 Replacement Parts

The following is a list of recommended AR ArrestAll replacement parts. For multiple collector systems, the quantities of each spare part should be adjusted accordingly. See AAF Form 1281 for proper part numbers.

ArrestAll Size	Cartridge	Shaker Module	Shaker Motor	Pocket Inserts		Cartridge Retainer	Cartridge Frame Assembly
				Wide Spacing	Extra Wide Spacing		
AR-1	1	1	1	16	8	1	1
AR-2	2	1	1	32	16	2	2
AR-3	3	1	1	48	24	3	3
AR-4	4	1	1	64	32	4	4
AR-6	6	1	1	96	48	6	6