



*Better Air is Our Business®*

## **AmericanAirFilter® Type W RotoClone®**

***Wet Centrifugal Collector***

***Installation, Operation,  
and Maintenance Instructions***

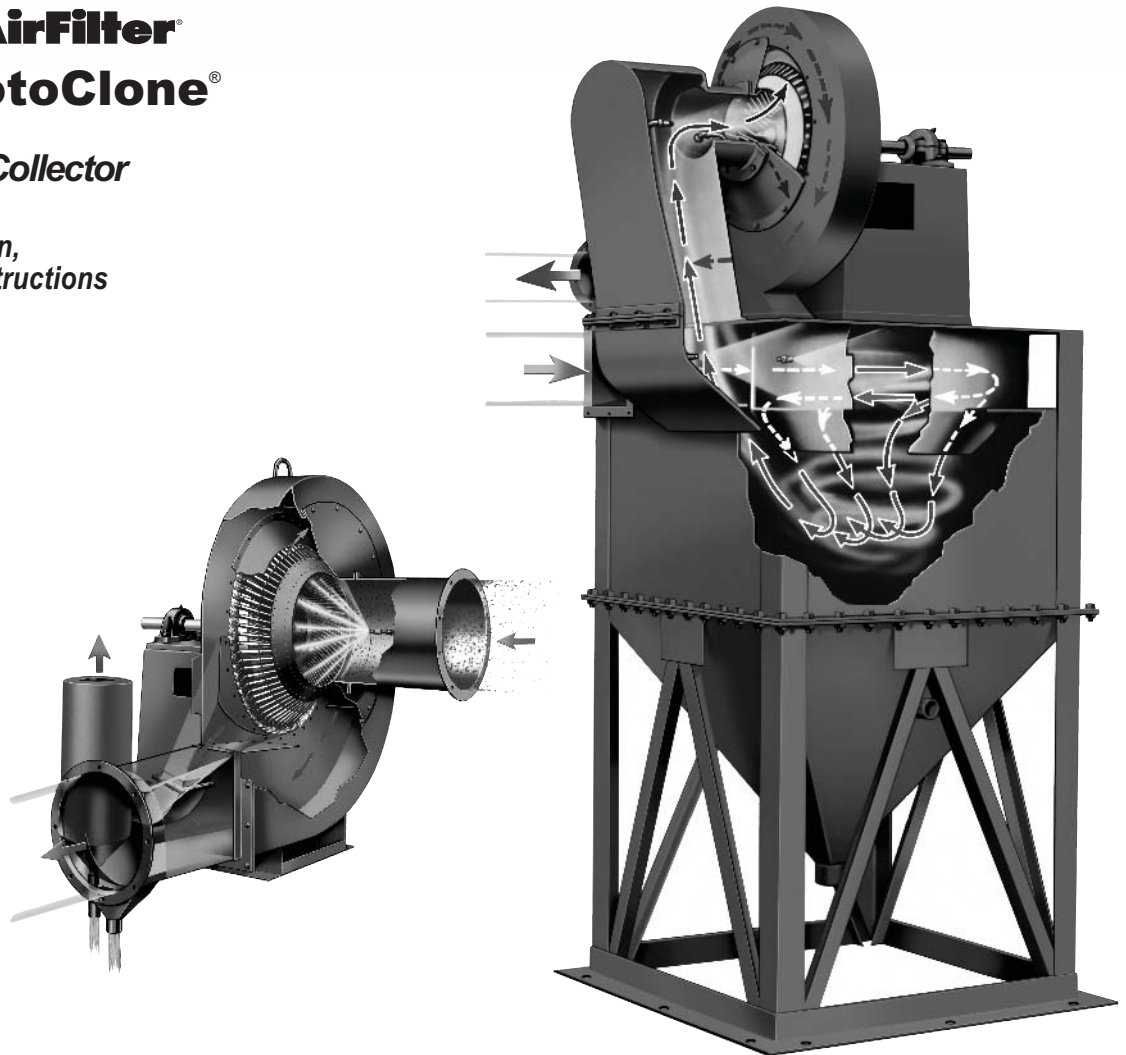

### ***IMPORTANT:***

Read this manual before installing or operating the equipment. This manual should remain with the equipment for reference regarding operation, maintenance and repair/parts. Write down the information from the nameplate on the W RotoClone and copy it to the front of this IOM for future reference.

Retain all drawings and documents that came with the RotoClone (in the "Instructions Envelope") and keep with the IOM in a readily accessible location.

If you are an installer and not the owner of this equipment, all of these documents should be submitted to the end user, upon completion of the installation.

## Table of Contents

### 1.0 Description

### 2.0 Installation

- 2.1 Foundations
- 2.2 RotoClone Erection (Arrangement A & D)
- 2.3 Duct Connections (Arrangement A & D)
- 2.4 Water Connections (Arrangement A & D)
- 2.5 Average Water Requirements
- 2.6 Wiring & Controls
- 2.7 Spray Nozzles
- 2.8 Sludge Connection (Arrangement A & D)
- 2.9 Drain Connection (Arrangement A & D)
- 2.10 Emergency Overflow (Arrangement D)
- 2.11 Bearings
- 2.12 Drive
- 2.13 Placing RotoClone in Service

### 3.0 Operation

### 4.0 Maintenance

- 4.1 Lubrication
- 4.2 Nozzles and Strainer
- 4.3 RotoClone Inlet (Arrangement A)
- 4.4 Precleaner Inlet (Arrangement D)
- 4.5 RotoClone Impeller
- 4.6 Drains
- 4.7 Emergency Overflow (Arrangement D)
- 4.8 Shaft Seal
- 4.9 Replacement of Shaft, Impeller or Water Cone

### 5.0 Troubleshooting

- 5.1 Water Entrainment
- 5.2 Dust Entrainment

### 6.0 Weights & Water usage Tables

### 7.0 Storage Instructions

### 8.0 Parts List

### 9.0 Supplements for Optional Features

- 9.1 Food Quality W RotoClones
- 9.2 Range Hood and FM Controls
- 9.3 Auxiliary Impeller Flushing

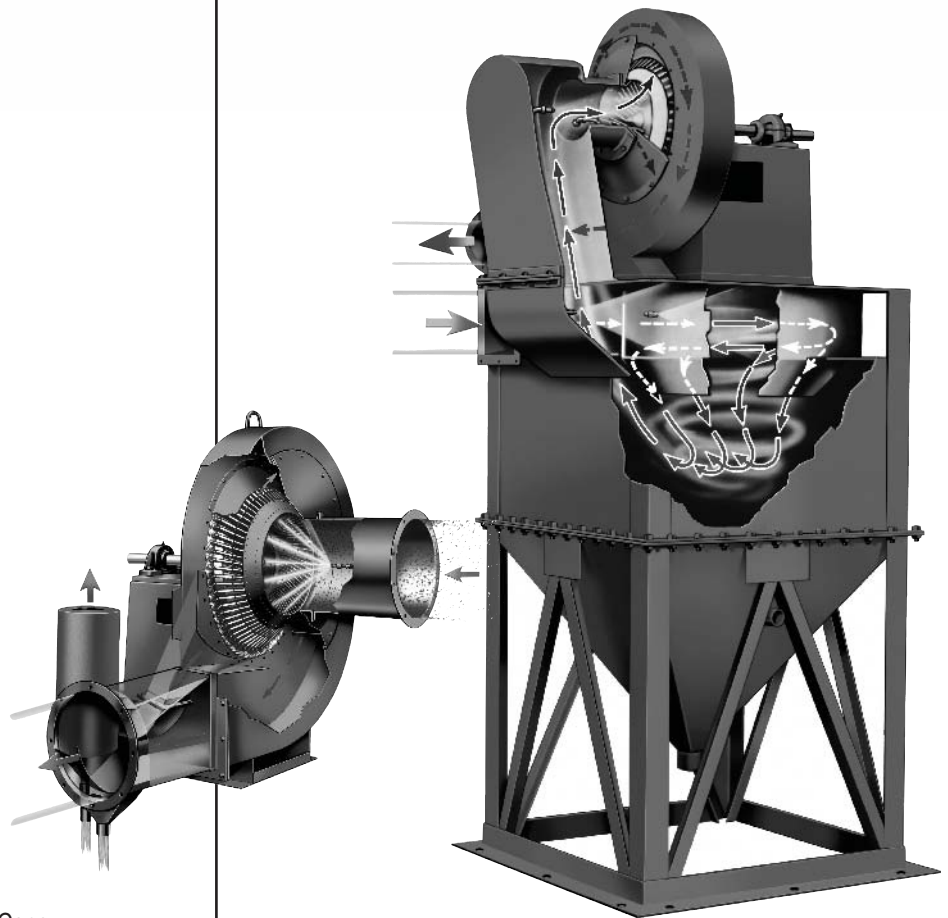

### 1.0 Description

The Type W RotoClone is a complete dust control unit. It combines exhaustor and dust collector in a single compact unit, and continuously discharges the collected material in a slurry form.

The Type W RotoClone has been designed to perform its various functions automatically and requires very little maintenance. Like any other mechanical equipment, however, it should have regular attention and be operated according to instructions to ensure long life and trouble-free service.

## 2.0 Installation

The following instructions should be read carefully before installing the RotoClone.

### 2.1 Foundations

Foundations must be true, level, and rigid enough to prevent vibration and support the weight of the RotoClone. (See Section 6, Table 2 for net weights of RotoClone.)

### 2.2 RotoClone Erection (Arrangement A)

Refer to Installation Diagram - Figure 1. Assembly of the RotoClone should proceed in the following manner sealing all joints using gaskets and bolts included with shipment. Some RotoClones, size 16 and smaller, have inlet, outlet, and expansion chamber welded to housing in lieu of flanged and bolted connections.

1. Bolt RotoClone outlet connection to RotoClone outlet. Be sure that the bottom of the outlet piece is even with the bottom of the RotoClone outlet and that no gasket material is protruding inside as this will cause water carryover.

2. Bolt RotoClone on foundation. If vibration isolators are used, a sub-base must be used to support the exhauster with the isolators located at each corner of the sub-base. Connecting ductwork requires flexible connections when vibration isolators are used.
3. Bolt RotoClone inlet connection to RotoClone inlet. (Note: Eliminate elbows and other inlet obstructions if at all possible. Sharp elbows at the fan inlet or other disturbances will seriously reduce the air volume and can affect the RotoClone's dust collection efficiency. A minimum of 4-5 inlet diameters of straight duct prior to the RotoClone is recommended to evenly distribute airflow.)
4. Bolt expansion chamber to water outlet.

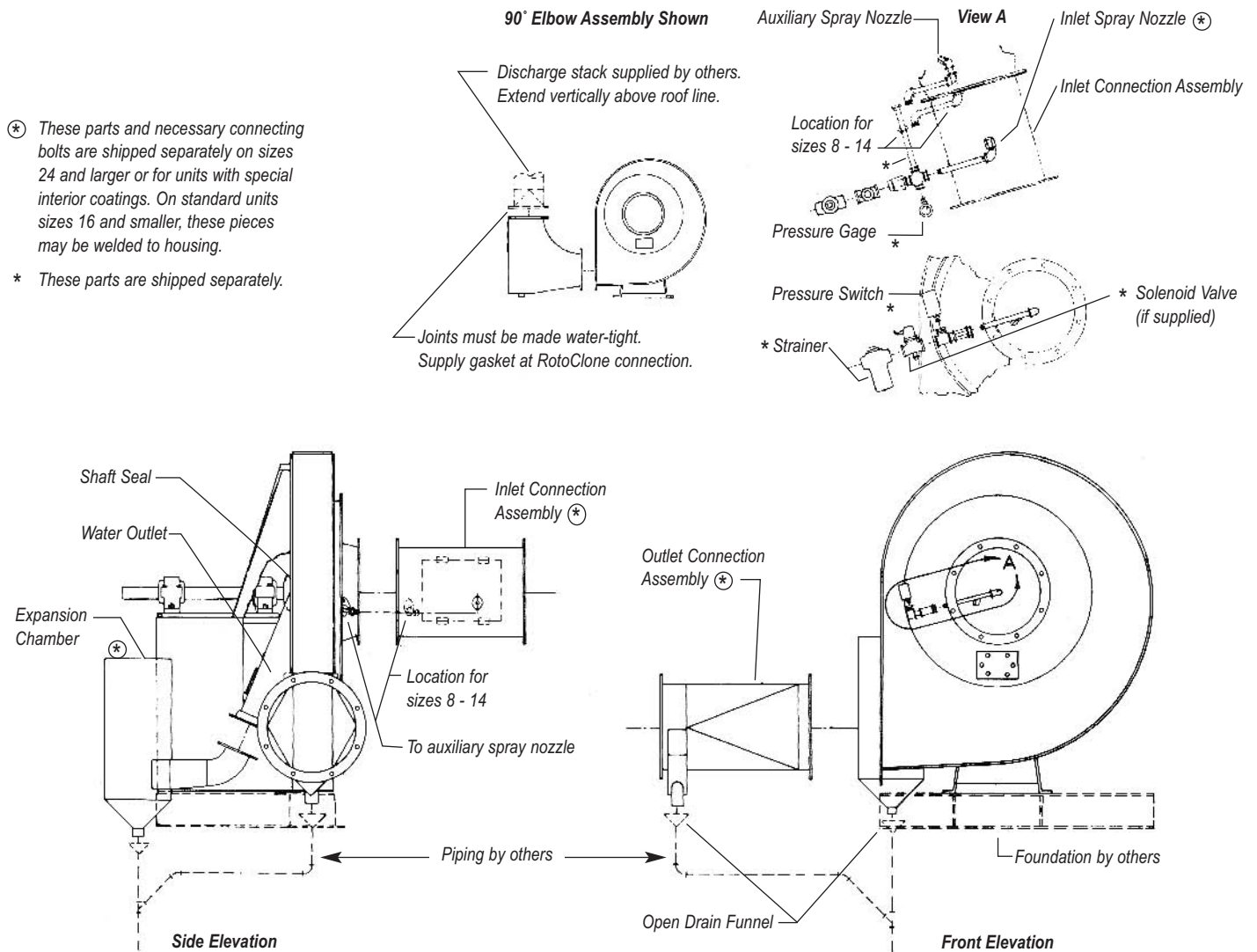

Figure 1 — Installation Diagram

### RotoClone Erection (Arrangement D)

Refer to Arrangement D Erection Diagram - Figure 2. Assembly should proceed in the following manner, using gaskets and bolts included with shipment for each joint. Some RotoClones, sizes 16 and smaller, may have inlet, outlet, and expansion chamber welded to housing in lieu of flanged and bolted connections.

1. Place hopper section on foundation and anchor.
2. Bolt precleaner section to hopper top. (Note: On RotoClones sizes 8 through 20, the hopper and precleaner sections are normally shipped assembled.)
3. Bolt RotoClone outlet connection to RotoClone outlet. Be sure that the bottom of the outlet piece is even with the bottom of the

RotoClone outlet and that no gasket material is protruding inside as this will cause water carryover.

4. Bolt RotoClone to precleaner top. (Note: On RotoClones sizes 8 and 10, RotoClone is shipped assembled to precleaner and hopper.)
5. Bolt precleaner outlet connection to precleaner section. (Note: On RotoClones sizes 8 through 16, the precleaner outlet connection and precleaner are shipped assembled.)
6. Bolt RotoClone inlet connection to RotoClone inlet and precleaner outlet connection.
7. Connect hose from water drain in RotoClone outlet connection to nipple provided in hopper using fittings provided.

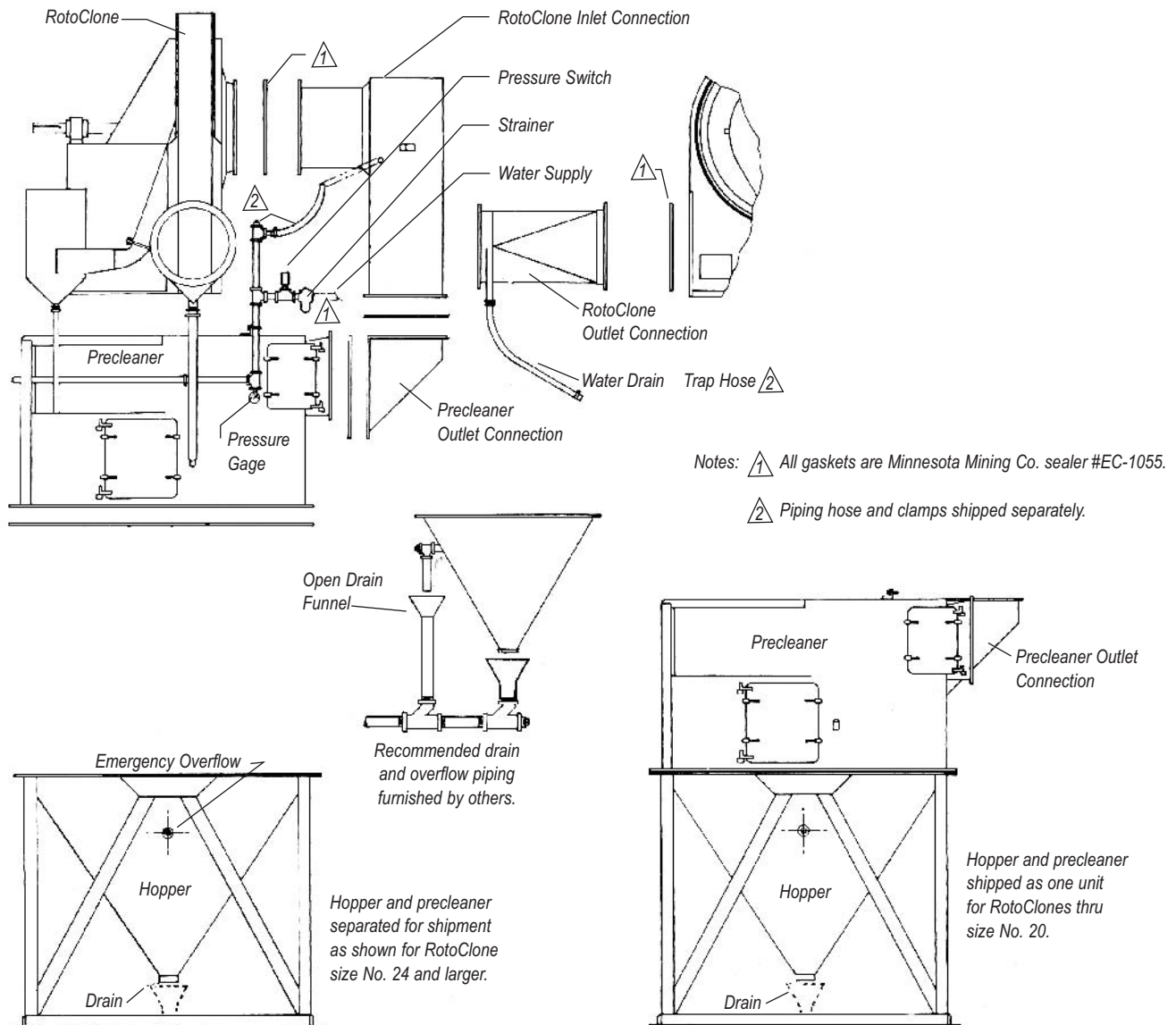

Figure 2 — Arrangement D Erection Diagram

### 2.3 Duct Connections (Arrangement A)

Inlet and discharge ducts must be supported from floor, wall, or ceiling, and not by the RotoClone. The joint between the RotoClone inlet and exhaust main must be water-tight. Inlet duct should slope downward with bottom of duct no lower than bottom of RotoClone inlet. There should be at least four (4) duct diameters of straight run leading to the inlet of the RotoClone or performance may be impaired. Discharge duct should extend above roof line and should discharge the air vertically upward. It should be of same diameter as the RotoClone inlet and seams must be soldered or welded water-tight. A gasket (not furnished) should be placed between the outlet connection and the discharge duct to make joint water-tight. A weather hood is not required. Expansion chamber should be vented per Figure 3, where recirculation of discharge air is not permitted.

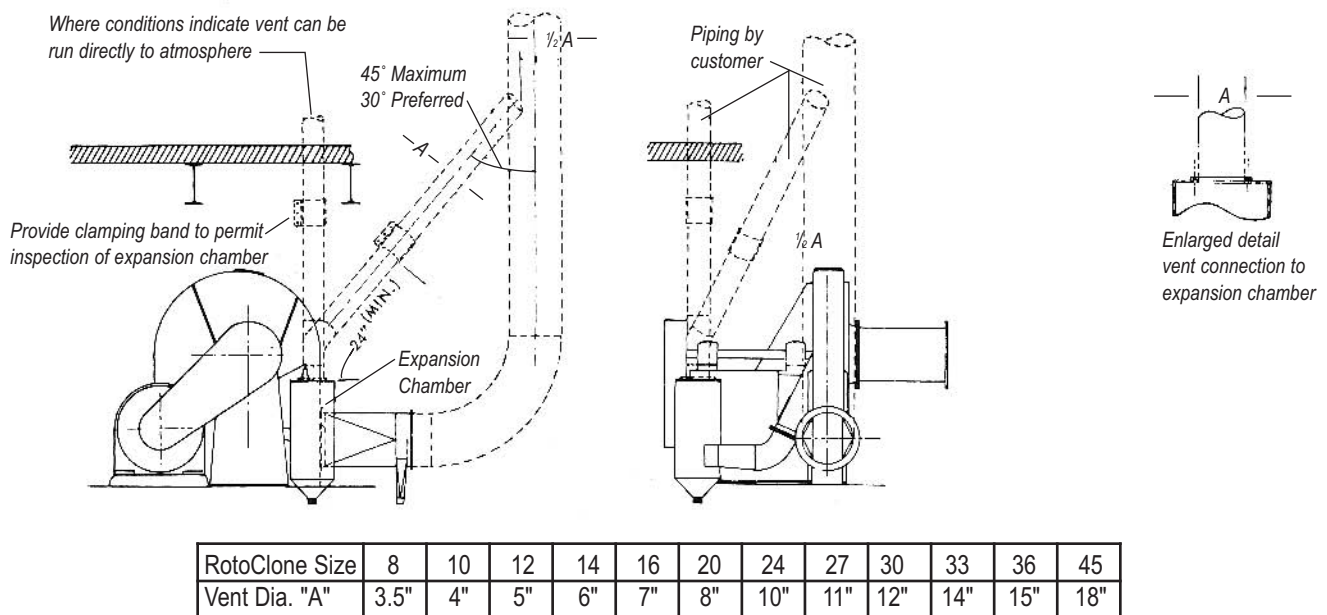

Figure 3 — Expansion Chamber Venting Diagram

### (Arrangement D)

Instructions same as Arrangement A except on Arrangement D, the joint between **Precleaner** inlet and exhaust main must be water-tight.

### 2.4 Water Connections (Arrangement A)

RotoClone piping may be shipped loose to prevent damage during shipping. Connect the two lines from the "cross" to the two connections on the RotoClone inlet. The third outlet from the cross connects to the pressure gauge supplied and the front leg should be connected to the water supply line. Supply line should be 3/4" size for RotoClones through size 14; 1" size for size 16 RotoClones and larger and designed for supply line water pressures. Connect the water supply line to strainer located near RotoClone inlet, using pipe at least as large as the strainer connection. The Solenoid Valve, should be installed between the strainer and cross, and should be wired in parallel with the RotoClone motor per the wiring diagram supplied with the unit. Solenoid valves should always be installed with the coil in the top, vertical position. Finished piping should be per Figure 1.

It is recommended that a manual shut-off valve be installed in the supply line, to be able to do maintenance on the solenoid valve. The water connection must be capable of supplying the volume listed in Section 6, Table 1 to the spray nozzles at 40 to 60 psi pressure.

### (Arrangement D)

Instructions same as Arrangement A, strainer located near Precleaner inlet. Refer to Figure 2 for Pressure Gage Installation.

**A by-pass connection with manual valve per Figure 4 (both Arrangement A and D) may be included to safeguard operation of RotoClone in case of solenoid valve failure or for strainer maintenance.**

### 2.5 Average Water Requirements

See Section 6.0, Table 1 for average water required.

### 2.6 Wiring & Controls

Refer to the wiring diagram supplied with the unit for recommended connections.

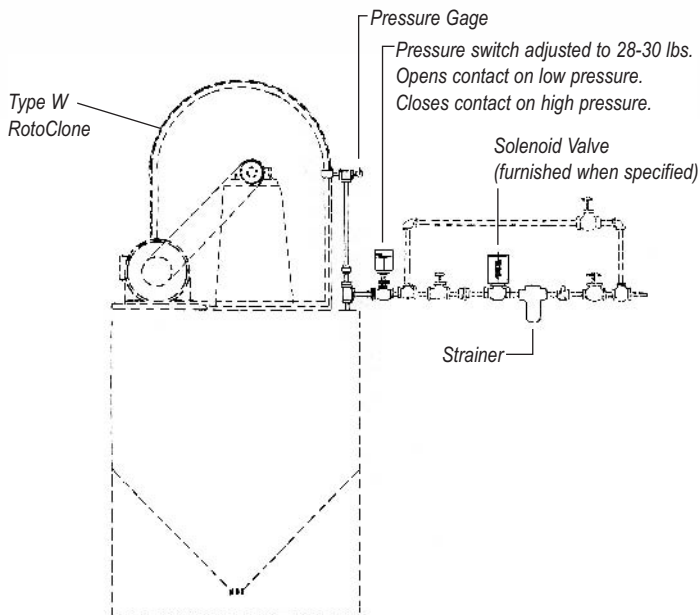

Figure 4 — Piping Diagram, Arrangements A and D

### 2.6A Pressure Switch

A switch is supplied with the RotoClone which will stop the RotoClone motor automatically when water supply fails or water pressure falls below 28 psi. This pressure switch should be mounted in the water supply line as shown in Figure 1 and wired as shown in the wiring diagram supplied with the unit. (Note: this switch is not supplied, when "Range Hood" controls are supplied - see Section 9.2 for Range Hood controls.)

When switch has stopped RotoClone motor because the water pressure has dropped below 28 PSI, RotoClone cannot be started again until water pressure has returned to not less than 30 PSI.

Switch has been adjusted at factory to operate in the range described above. Switch setting may be checked against pressure gage reading. To readjust, remove cover and turn adjustment screw to right or left, using pressure gage as a guide.

### 2.6B FM Range Hood Controls (Optional)

These controls are designed to prevent fires in kitchen range hoods beyond the RotoClone outlet when wired according to Drawing U48P-46209 (except NY), U48P-1427848 (NY), U48P-1653872 (Can), or the specific wiring diagram supplied with the unit. These controls, when supplied, include two solenoid valves, two flow control switches (these replace the pressure switch), Fenwal Detect-A-Fire switch, and relays. (See Section 9.2 for additional details on this option.)

### 2.7 Spray Nozzles (Arrangement A)

Nozzles are installed at the factory. Connect the nozzle piping to the fittings provided. From the strainer the main pipe leads to the conical spray nozzle fitted in the RotoClone inlet connection. The small

branch line leads to auxiliary flat spray nozzle within the RotoClone housing. Refer to installation diagram, Figure 1; flat spray should be in the 7 o'clock position with "fan" parallel to the blades of the impeller.

### Spray Nozzles (Arrangement D)

Nozzles are installed at the factory. Connect nozzle piping to the fittings provided. Refer to erection diagram, Figure 2. From the strainer, the main line branches into two connections, one leading to two or more vertical flat spray nozzles fitted at the precleaner inlet and the other one to a conical spray nozzle fitted into the RotoClone inlet connection. From this line, a small branch leads to an auxiliary flat spray nozzle within the RotoClone housing.

### 2.8 Sludge Connection (Arrangement A)

The expansion chamber and outlet connection drains should discharge to an open funnel, so if drain piping plugs up, water will run over funnel and not back up in RotoClone which may cause damage. See Figure 1. Piping from funnel should be equal or larger in size than expansion chamber nipple. This connection can run to (1) sewer or drain line, (2) process, (3) settling tank, or (4) other locations dependent on local conditions/regulations and the amount of material collected by the RotoClone.

### (Arrangement D)

The hopper drain should discharge into an open funnel. See Figure 2. Piping from the funnel should be equal or larger in size than the hopper drain opening. The sludge can be disposed the same as suggested under Arrangement A.

### 2.9 Drain Connection (Arrangement A)

The drain from the outlet connection, see Figure 1, should be connected to the sludge pipe from expansion chamber or directly to a drain. Full size piping should be used. Refer to installation diagram Figure 1. Note that a funnel is shown under the drain. This provides easy access to the drain if an obstruction should occur. A plugged drain can cause the water level in the collector to rise into the impeller and the impeller tips will break.

### (Arrangement D)

The drain from the outlet connection should be piped back into the RotoClone hopper (see Figure 2).

### 2.10 Emergency Overflow (Arrangement D only)

Connect pipe nipple located on hopper side to open drain funnel using same size pipe. See Figure 2. Connection from funnel to sludge line must be no smaller than main drain connection at bottom of RotoClone hopper.

### 2.11 Bearings

RotoClone bearings are of the ball or roller-bearing type and are packed with proper amounts of grease before leaving the factory. Additional grease need not be added at the time of installation. Both a "fixed" and "floating" bearing are used. For optimum life, the "fixed" bearing is located on the outboard position (drive side).



### 2.12 Drive

Type W RotoClones are belt-driven. Motor, if supplied by others, should be equipped with adjustable slide base. Short center V-belt drive, if provided by others, is the preferred arrangement. V-belt drives are usually mounted by the factory in an Arrangement 9 motor mounting. Where the motor mounting is Arrangement 1 or the motor and drive are too large to be shipped mounted on the unit, refer to belt manufacturer's recommendations for belt tension, or call AAF for instructions. Improper tension will affect performance and life of the drive and bearings.

### 2.13 Placing RotoClone in Service

To make sure impeller is free, turn shaft by hand before starting RotoClone. THE DIRECTION OF ROTATION MUST BE COUNTER-CLOCKWISE when viewed from the drive side of RotoClone.

#### Note arrow on housing.

Flush strainer to remove pipe scale and solids from supply line.

Paper, wood, and other foreign materials are frequently left in exhaust system during erection. Inspect RotoClone impeller through inspection doors located at RotoClone inlet and rear housing before operating the unit and after 24 hours operation. Remove any such accumulations conveyed to the RotoClone impeller, and check all drains for blockage.

## 3.0 Operation

### TO START RotoClone:

1. Open valve in water supply line (unless automatically controlled).
2. Start RotoClone motor.

### TO STOP RotoClone:

1. Stop RotoClone motor.
2. Close valve in water supply line (unless automatically controlled).

**CAUTION:** Pressure in water supply line to spray nozzles must be maintained at 40 lb. per inch or higher during RotoClone operation.

Do not permit paper, waste, or similar large pieces of material to be thrown into suction hoods because they will plug RotoClone and cause water and dust to escape through clean air discharge or will plug drains, allowing water to build up and damage the impeller.

## 4.0 Maintenance

### 4.1 Lubrication

Flush and refill pillow block bearings on RotoClone shaft per attached schedule. Using amounts listed below. #2 S.R.I. type grease is recommended.

For 2 piece split bearings, 12 hr/day, 5 day/wk operation, the bearings should be lubricated every 6 months, as follows (Note: this type of bearing should not be over greased).

<b>RotoClone Size</b>	8	10	12	14	16	20	24	27	30	33	36
<b>Oz. of grease per Bearing</b>	2	2	3	4	10	10	16	22	28	32	36

For single piece bearings, the following minimum schedule should be followed for 12 hr/day, 5 day/wk operations. This type of bearing can be greased until old grease is forced out of seals.

RotoClone Size	Cu. In. Grease	Lubrication Interval		
		6 mos Max Operating Speed (RPM)	4 mos	2 mos
8	0.3	2400	3600	5000
10	0.3	2400	3600	
12	0.4	2000	3000	
14	0.8	1700	2500	
16	0.8	1450	2200	
20	0.8	1450	2200	
24	1.2	1300	1900	
27	1.7	1200	1800	
30	2.3	1100		
33	3.1	1000		
36	3.1	1000		
45	4.3	900		

Grease shaft seal at same time as bearings. Water leakage is an indication of insufficient grease.

### 4.2 Nozzles and Strainer

Flush out strainer periodically and inspect spray nozzles for proper water delivery and pattern. Since water quality varies, a monthly inspection, for the first year of operation is recommended, in order to determine a maintenance schedule.

### 4.3 RotoClone Inlet (Arrangement A)

Open inspection door at RotoClone inlet connection and remove any accumulation in the inlet at the border line of the wet and dry section. The frequency of cleaning varies for each installation and must be determined by frequent inspection when RotoClone is first placed in service. Clean out before accumulation obstructs one-tenth of cross section area or inlet connection. Clean sludge from RotoClone inlet door before closing.

### 4.4 Precleaner Inlet (Arrangement D)

Under certain operating conditions, a deposit of dust will occur at the border line of the dry and wet zones in the precleaner inlet. The removal of this deposit must become a part of regular maintenance. The frequency of removal can be established only by periodic inspections when the RotoClone is first put in operation. The deposit should never be allowed to obstruct more than one quarter of the area of the precleaner inlet.

A door is provided at the precleaner inlet to remove this accumulation. Be sure spray nozzle is not damaged or clogged and that nozzle orifice is vertical. Gasket seal should be cleaned before closing inlet door.

#### 4.5 RotoClone Impeller

Inspect the RotoClone impeller periodically for accumulations of foreign material or obstructions in blade hooks. The blade hooks formed by the leaving edge of the impeller blades convey the collected dust and water out of the airstream. A build up of dust within these hooks may be sufficient to cause pronounced vibration or dust and water entrainment. Such accumulations should be removed either by flushing with high velocity water jet or scraping with long screw driver through access door in back of RotoClone housing and from front side of impeller.

Flat spray of flushing nozzle located at impeller (7 o'clock position, viewed from the inlet) should be parallel to blade edges. Check this spray with water on periodically to ensure proper positioning and spray pattern.

Certain accumulations in RotoClone impeller cause no difficulty and can be disregarded. They include minor deposits on back of impeller blades, slight coating or small deposits on front side of blades, and slight deposits in blade hooks that do not obstruct flow of dust and water.

#### 4.6 Drains

Keep all drains clean. If necessary flush out periodically. A plugged drain can cause damage to the impeller. Inspect grating in bottom of the Arr. D RotoClone hopper periodically and remove any accumulation.

#### 4.7 Emergency Overflow (Arrangement D only)

An emergency overflow is provided on side of hopper to drain off the water in case hopper drain pipe becomes clogged. This stoppage must be cleared immediately.

#### 4.8 Shaft Seal

Other than routine greasing of the shaft seal (see 4.1 Lubrication), the shaft seal requires no maintenance. Should the seal fail, replacement of the two seals as shown in Figure 5 may be necessary. Since the seals are "split" it is usually not necessary to remove anything, other than the seals, from the shaft itself, unless damage to the seal housing or metal spacer (located between the two seals) is evident. On the smaller RotoClones, it may be necessary to loosen the bearing closest to the seal and move it back about 6 inches, to gain clearance to remove the seal housing. Be certain that the position of the shaft in relation to the RotoClone is not changed in any direction when doing this.

1. Remove the seal housing by removing the nuts securing it to the scroll, and slide the housing back, exposing the seals and spacer. Discard old seals.
2. Inspect the shaft and seal housing to insure that they are clean and smooth. Remove any rust buildup with emery cloth or steel wool. Inspect metal spacer; replace if necessary (this will require removing bearings to slip spacer off the shaft and install new spacer. Be sure to reposition impeller per Figure 6, before tightening bearings back in place).
3. Place a small amount of silicone sealant between the radial cut on each seal.
4. Install the new seals on either side of the spacer with the radial cut at the top and the garter springs circling the inner lip of each seal.
5. Insure that the radial cut in the metal spacer is located directly below the grease fitting in the seal housing to allow grease flow.
6. Install the seal housing and tighten the nuts.
7. Lubricate the seal thoroughly with No. 2 grease.
8. Replace any bearings, if removed, in original position and check impeller clearance per Figure 6 before tightening bearings onto shaft.

## Shaft Assembly — Arrangements A and D

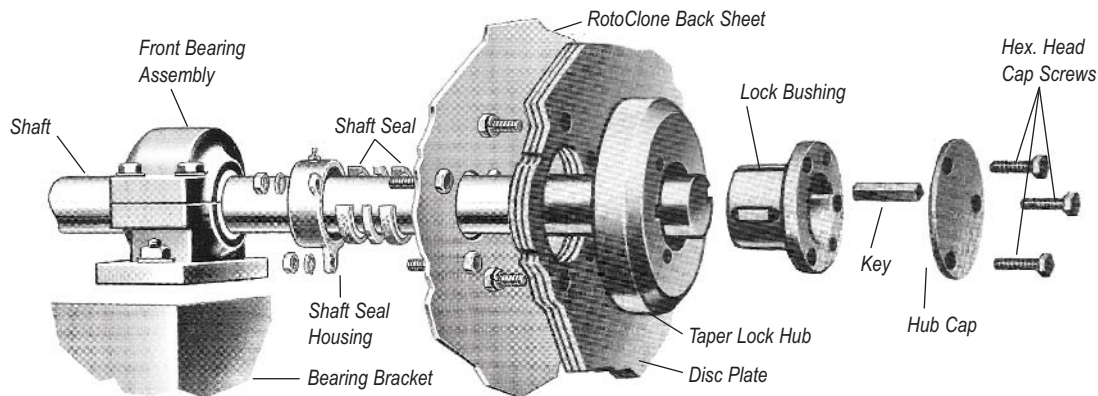

Figure 5 — Construction details of Type W RotoClone Shaft Assembly showing heavy duty bearings, oversized shaft, watertight shaft seal, laminated impeller disc, and cast iron hub with taper lock for easy impeller removal.

### 4.9 Replacement of Shaft, Impeller or Water Cone

Removal of the shaft, impeller, or water cone requires access to the front of the scroll. This is most easily accomplished by removing the inlet piece and scroll inlet cone. The water piping should be disconnected before removing the inlet sections. The water cone should be marked to indicate the bolt hole locations in relation to the scroll, before removal. The old water cone can be used to match mark the replacement water cone, which comes undrilled. Note the distance from the back of the impeller to the scroll before removing the impeller. The impeller is fastened to the shaft by a taper lock hub.

It is easiest to remove the impeller from the shaft by using a wheel puller, after unbolting the hub; or one can reinsert the hub screws into the unused holes in the hub to “push” the shaft off of the hub. However, on units that have been in service for years, this method may not provide the necessary force to “break” the hub away from the shaft, and the wheel puller will be necessary. Finally, the bearings and driven sheave are taken off and the shaft can be removed.

Reinstallation is the reverse of removal. The shaft is replaced and the bearings and driven sheave tightened back onto it. New set screws should be used, when single piece bearings are supplied, as the old ones will most likely have blunted ends that can no longer adequately

secure the collar to the shaft. Be sure to tighten the set screws to the proper torque as recommended by the bearing supplier (or contact AAF for recommendation). The impeller is reattached to the shaft, but the taper lock hub screws are not tightened yet. All old gasketing material should be removed from the scroll and water cone. A new water cone gasket should be cemented to the water cone. The water cone is then reattached to the scroll using the match marks to orient it in the same position as the original. The impeller is then checked for proper distance from the water cone edge using Figure 6 and the Table on page 10.

The taper lock hub screws are tightened After confirming the proper position of the impeller. Note that the impeller may shift as the hub is tightened onto the shaft; the impeller position should be checked while tightening the hub and repositioned as necessary. A wooden block and hammer can be used to “tap” the impeller back if required. Recheck the impeller position and rotate the impeller to insure that it turns freely, once the impeller is locked onto the shaft. The inlet pieces and piping can then be reattached. A waterproof caulking/gasket is used between the inlet flanges; remove any old material before reinstalling, and be sure to encircle bolt holes with caulk, or leaks may result.

- ⚠ New shaft with key for lock hub.
- ⚠ Key to adapt old shaft to lock hub.
- ⚠ On sizes 30-36, hub cap mounts flush with hub.

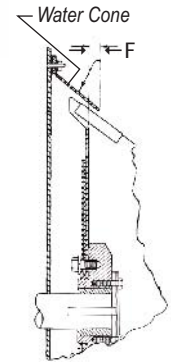
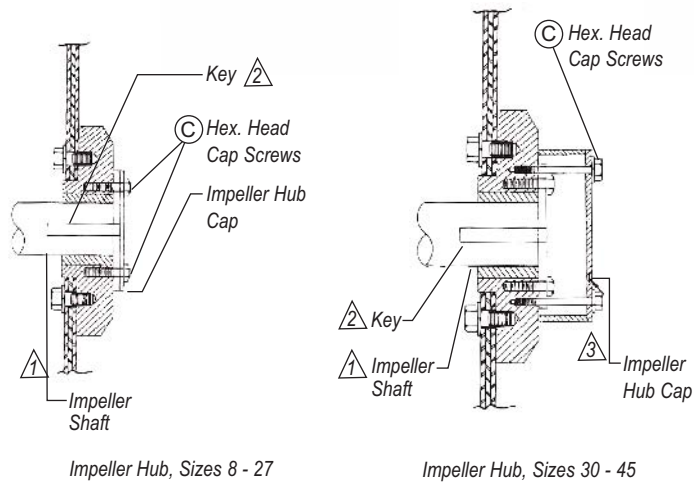

See Table below to check impeller for proper distance from the water cone edge.

Figure 6 — Field Replacement of W RotoClone Impeller

Table: Distance of Impeller from Water Cone

RotoClone Size	C = Cap Screws	F = Impeller Clearance
8	3/8 - 16 X 1	5/16 - 7/16
10	3/8 - 16 X 1	7/16 - 9/16
12	3/4 - 10 X 1	9/16 - 11/16
14	3/4 - 10 X 1	9/16 - 11/16
16	3/4 - 10 X 1	5/8 - 7/8
20	3/4 - 10 X 1	13/16 - 1-1/16
24	3/4 - 10 X 1	1-1/8 - 1-3/8
27	3/4 - 10 X 1	1-1/8 X 1-3/8
30	5/8 - 10 X 1	1-5/16 - 1-11/16
33	3/4 - 10 X 1	1-5/16 - 1-11/16
36	3/4 - 10 X 1	1-5/8 - 1-15/16
45	3/4 - 10 X 2-3/4	2 - 2-1/2



## 5.0 Troubleshooting

**5.1 Water Entrainment** - Excessive discharge of water in the exhaust may be due to the following:

- Incorrect rotation (correct rotation is counter-clockwise, when viewed from the drive end).
- Incorrect size cone spray or auxiliary nozzles and incorrect spray pattern (i.e. flat spray at 7 o'clock position viewed from the inlet and parallel to blades and cone spray to be centered at wheel). Inlet spray should just miss inlet perimeter as it passes into the scroll.
- Disturbances at inlet, such as elbows or branch entries, causing unbalanced airflow or dust loading (see Section 2.3).
- Bent blade tips and/or obstructions in impeller such as rags, collected material buildup, etc.
- Pluggage of drains.
- Incorrect outlet piece location. The bottom of the outlet piece should never be above the bottom of the RotoClone scroll. Any gasketing that has squeezed out should be removed.
- Improper gasketing of water cone, or damage/wear of the water cone.
- Incorrect water pressure.

**5.2 Dust Entrainment** - Excessive entrainment of dust with the cleaned air may be due to the following:

- Equipment running dry or with insufficient water - because of clogged spray nozzles or strainer, or low water pressure, (40 lb. minimum pressure required at nozzles).
- Obstructions in impeller blade hooks.
- On Arrangement D, spray nozzle in precleaner turned. Flat spray must discharge in a vertical plane.
- Dust loading too heavy.
- Particulate size too small to be captured.
- Disturbances at inlet, such as elbows or branch entries, causing unbalanced airflow or dust loading (see Section 2.3).

## 6.0 Weights & Water Usage Tables

Table 1. Normal Water Supply Rates - Type W RotoClones

Size	Arrangement A			Arrangement D		
	GPM Supplied			GPM Supplied		
	40 psi	50 psi	60 psi	40 psi	50 psi	60 psi
8	1.1	1.2	1.3	2.1	2.2	2.5
10	1.5	1.6	1.8	3.1	3.4	3.8
12	1.8	2.0	2.2	4.8	5.4	5.9
14	2.3	2.5	2.9	5.3	5.9	6.5
16	3.5	3.9	4.3	7.5	8.4	9.2
20	4.5	5.0	5.5	8.5	9.5	10.4
24	5.5-6.0	6.2-6.7	6.8-7.3	13.5-14.0	15.1-15.6	16.6-17.1
27	7.0-7.5	7.9-8.4	8.7-9.2	----	----	----
30	8.0	8.9	9.8	----	----	----
33	12.0	13.4	14.7	----	----	----
36	14.0-15.0	14.7-15.7	16.7-17.1	----	----	----
45	21.0-22.0	23.6-24.6	25.9-26.9	----	----	----

**NOTE 1:** Decreased or increased water requirements can be provided by changing nozzle size.

**NOTE 2:** For air temperatures in excess of 300° F cooling spray nozzles should be provided in inlet duct to compensate for evaporation. A safe approximation will be 0.2 GPM of additional water per 1000 CFM for each 100° F temperature reduction.

Table 2. Shipping and Operating Weight in Pounds

RotoClone Size	Arrangement A		Arrangement D	
	Shipping Weight (lbs.)	Operating Weight (lbs.)	Shipping Weight (lbs.)	Operating weight (lbs.)
8	225	425	1,725	2,625
10	360	610	1,810	3,010
12	630	880	2,030	3,380
14	990	1,340	2,790	5,320
16	1,260	1,710	3,760	6,310
20	1,620	2,270	5,420	9,650
24	1,890	2,590	7,190	13,290
27	2,970	3,720	--	--
30	3,870	5,020	--	--
33	4,860	6,360	--	--
36	5,850	7,350	--	--
45	13,500	16,000	--	--

**NOTE 1:** Shipping weight does not include motor and drive.

**NOTE 2:** Operating weight includes estimated weight for motor and drive for Arrangements "A" and "D". Also includes maximum sludge capacity based on 100 lb. per cubic foot for Arrangement D hopper in the event of plugged drain line.

**Table 3. Spray Nozzles For Type W RotoClones**

Size	(1) Inlet Nozzle (GPM)	(2) Impeller Auxiliary Nozzle (GPM)	(2) Arr. D Precleaner Nozzles (GPM)	Total Water Requirements @40 psi	
				Arr. A	Arr. D
8	0.6	0.5	0.5	1.1	2.1
10	1.0	0.5	0.8	1.5	3.1
12	1.0	0.8	1.5	1.8	4.8
14	1.5	0.8	1.5	2.3	5.3
16	2.0	1.5	2.0	3.5	7.5
20	3.0	1.5	2.0	4.5	8.5
24	3.5 to 4.0	2.0	4.0	5.5-6.0	13.5-14.0
27	5.0 to 5.5	2.0	--	7.0-7.5	--
30	6.0	2.0	--	8.0	--
33	8.0	4.0	--	12.0	--
36	10.0 to 11.0	4.0	--	14.0-15.0	--
45	15.0 to 17.0	6.0	--	21.0-22.0	--

(1) Hollow cone nozzle with 70° to 90° spray pattern.

(2) 80° to 90° flat spray pattern.

### 7.0 Storage

Temporary (30 days or less) storage of W RotoClones should be indoors in a controlled atmosphere, free from dirt and moisture.

Long term (greater than 30 days) storage should include the following:

1. Motor shaft and flanges to be coated with easily removable rust preventative Tectyl No. 502 C manufactured by Ashland Oil and Refining Co., or equal.
2. Block all openings to prevent rodents and small animals from nesting inside.
3. Insert silica gel desiccant in control boxes and motor junction boxes.
4. Cover units completely to exclude dirt, dust, moisture and other foreign materials. If possible, insert motor in strong, transparent plastic bag. Attach moisture indicator to side of motor, place several bags of silica gel inside, then seal plastic bag. If motor cannot be placed in plastic bag and relative humidity exceeds 50%, use space heaters to keep motor at least 10°F above ambient air temperature.
5. Rotate motor shaft at least 10 revolutions every month; relubricate bearings after each year of storage.
6. Check desiccant bags and rust preventative monthly; replace desiccant and recoat with rust preventative as required. Also check operation of space heaters.

## 8.0 Parts List

When ordering Replacement Parts, customer must state Serial Number and Size of RotoClone, Part Name (when shown on drawing) and Item Number.

### Taper Lock Type Hub (Views A-3 & A-4)

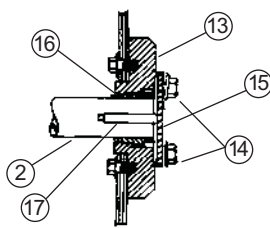

View A-3  
For Sizes 8 - 27

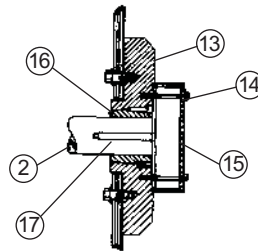

View A-4  
For Sizes 30 - 45

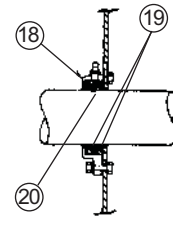

View B  
Shaft Seal Assembly  
Shown on 48P-1324680

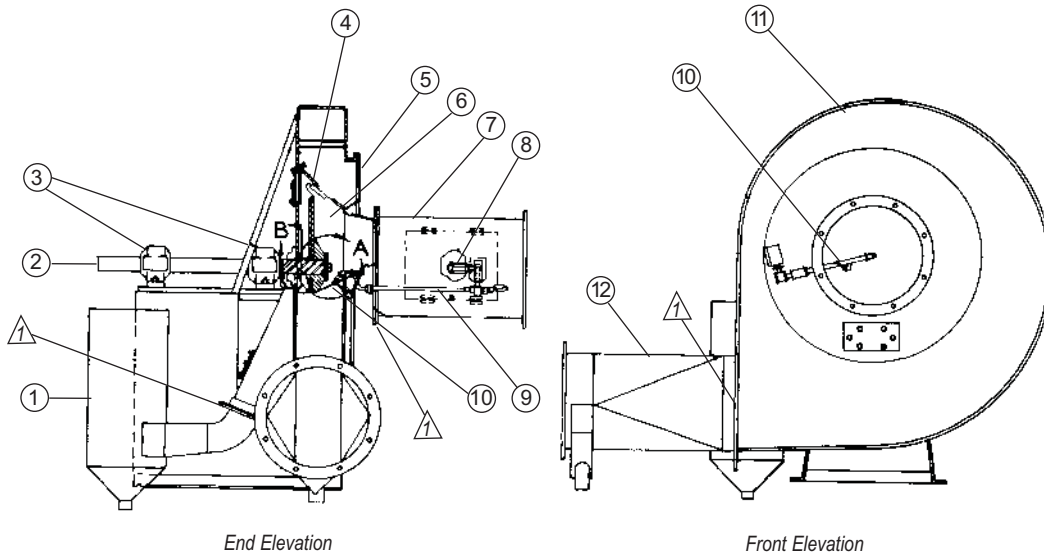

### Type W RotoClone Parts List:

- |                               |                           |   |
|-------------------------------|---------------------------|---|
| 1. Expansion Chamber Assembly | 11. Housing Assembly      | 1. Standard RotoClones, sizes 16 and smaller, may have inlet, outlet, and expansion chamber welded to housing in lieu of flanged and bolted connection. |
| 2. Impeller Shaft             | 12. Outlet Connection     |   |
| 3. Bearing, Shown on          | 13. Impeller Hub          | 2. Seal consists of two Buna-N pieces and two garter springs. Radial cuts should be sealed with silicon caulk when installing new seal.                 |
| 4. Water Cone Assembly        | 14. Hex. Head Cap Screws  |   |
| 5. Inlet Cone Assembly        | 15. Impeller Hub Cap      |   |
| 6. Impeller Assembly          | 16. Taper Lock Bushing    |   |
| 7. Inlet Connection           | 17. Key                   |   |
| 8. Cone Spray Nozzle          | 18. Seal Housing Assembly |   |
| 9. Piping Assembly            | 19. Shaft Seal 2          |   |
| 10. Monarch Figure 624 Nozzle | 20. Spacer                |   |

## 9.0 Supplements For Optional Features

### 9.1 Food Quality W RotoClones

"Food Quality" refers to features on the W RotoClone that make it readily accessible for interior cleaning and exterior finishing to facilitate washdown by minimizing surfaces that can collect and trap material or water. These features include quick opening access doors in the Inlet Section, Expansion Chamber, and 90° Elbow Outlet or Centrifugal Outlet (if supplied in lieu of the standard Straight Outlet); exterior welds ground smooth; and, construction features to eliminate or minimize flat, horizontal surfaces. Additionally, nozzles are installed in the Expansion Chamber and the 90° Elbow Outlet or Centrifugal Outlet (if supplied in lieu of the standard Straight Outlet), to facilitate removal of build up in the drain area.

#### 9.1A Installation and Operation

Installation and Operation procedure is the same as shown in Sections 2 and 3 of this IOM, with the exception of the requirement for extra water connections. Additional, valved, 40 psi, water supply connections should be made for the spray nozzle connections (screwed coupling(s) - see general Arrangement drawing for location(s)) in the Expansion Chamber and 90° Elbow or Centrifugal Outlet (if other than the Straight Outlet is supplied). It is recommended that the valves be opened intermittently, for a brief period, during RotoClone operation and at shutdown, to facilitate flushing of material that can accumulate and plug the drains. Frequency and duration of the water spray must be determined individually for each RotoClone application. (Provision can be made for automatic operation, by installing solenoid valves, actuated by timers.)

Note: Leaving the water "on" during operation of the RotoClone can result in water carryover in the exhaust duct; and, will result in excessive water consumption. An empirically determined timed sequence should be adequate to keep drains free-flowing, and is the recommended operational approach.

#### 9.1B Maintenance

Maintenance is the same as described in the basic IOM instructions, section 4.0. Special attention should be paid to the spray nozzles and areas where there are quick opening access doors. These areas often require more frequent cleaning. It is recommended that a preventative maintenance schedule be developed specific to each W RotoClone.

### 9.2 Range Hood and FM Controls

RotoClones provided with Range Hood or FM controls have slightly different inlet piping and controls than the standard W RotoClone. The Range Hood RotoClones have two (2) flow switches, two (2) solenoid valves, and extra inlet nozzle(s); and, no pressure switch, as described in the main IOM - see Figure 7. Additionally, there is

an electrical control box that houses relays and terminal strips, and a temperature switch to be installed in the ductwork upstream of the RotoClone. The piping assembly with the solenoid valves and flow switches, pressure gauge and strainer, ships loose along with the temperature switch and electrical control box - see the specific wiring diagram in the electrical control box (or in the envelope with the other IOM documents) for proper wiring, and sequence of operation.

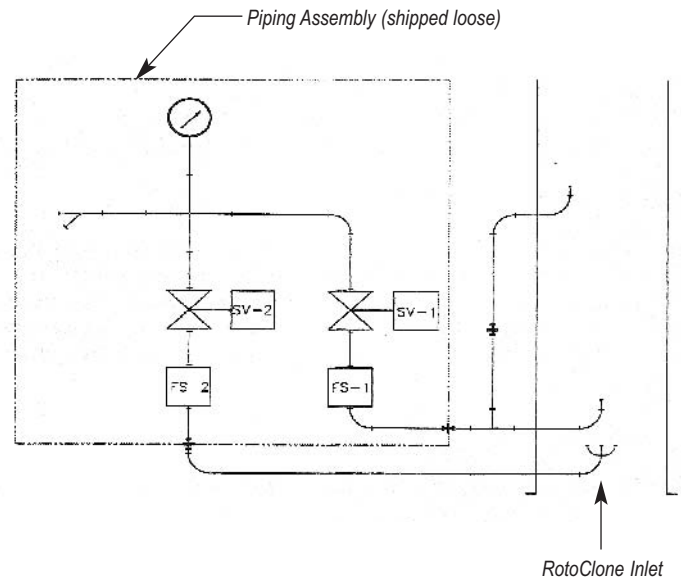

Figure 7: Flow Switches and Solenoid Valves

#### 9.2A Flow Switches

Flow switches are shipped assembled on the external piping assembly, which is shipped loose. They are referred to as FS-1 and FS-2. Flow switch FS-1 is connected to the standard inlet nozzle and the impeller flushing (auxiliary) nozzle. Flow switch FS-2 is connected to the emergency spray nozzle(s). Flow switches are set at the factory and should not be field adjusted. Each flow switch is set for a specific flow and are not interchangeable. The flow switches need only be wired up according to the separate wiring diagram included with the other IOM documents.

#### 9.2B Solenoid Valves

The solenoid valves (SV-1 and SV-2) are shipped assembled on the external piping assembly, which is shipped loose. The solenoid valves are identical and interchangeable; and, need only be wired up according to the separate wiring diagram included with the other IOM documents.

# AmericanAirFilter®

## Type W RotoClone®

### 9.2C Water Connection

The “shipped loose” piping assembly is attached to the RotoClone at the two unions on the end of the loose piping and connecting pieces on the RotoClone. Connect the water supply line to the strainer on the other end of the RotoClone piping assembly. It is recommended that a manual shut off valve (supplied by others) be installed in the supply line to facilitate maintenance on the flow switches and solenoid valves. The water connection should be capable of supplying the volume listed below at a pressure of 40 psi.

### Water Requirements

W RotoClone Size	8	10	12	14	16	20	24	27	30	33	36	45
Normal (GPM)	1.1	1.5	1.8	2.3	3.5	4.5	6.0	7.5	8.0	12.0	14.0	22.0
Emergency (GPM)	1.3	4.0	4.0	3.2	4.0	6.0	6.0	12.0	12.0	14.0	14.0	30.0
Combined (GPM)	2.4	5.5	5.8	5.5	7.5	10.5	12.0	19.5	20.0	26.0	28.0	52.0

### 9.2D Temperature Switch

The temperature switch comes attached to its own conduit box. The switch should be installed in an unobstructed portion of the ductwork between the RotoClone inlet and the Exhaust hood, where the thermal path is not hindered. It must be installed in the top of the ductwork so that the temperature switch/probe is hanging vertically. The switch/probe is installed in the duct by screwing the switch/probe through the duct and into the bushing in the conduit box until tight. This secures both the switch/probe and the conduit box to the duct.

### 9.2E Operation

Refer to the specific Range Hood wiring diagram in the IOM packet, for sequence of operation.

### 9.2F Maintenance & Troubleshooting

Refer to Sections 4 and 5 of this IOM for maintenance and cause of entrainment problems.

#### RotoClone won't start or stay running

Water pressure or flow insufficient to actuate flow switch(es).

- Supply water pressure less than 40 psi
- Nozzles plugged
- Strainer plugged
- Water usage elsewhere causes momentary interruption in flow to RotoClone
- Solenoid valve malfunctioning

Flow switch wired incorrectly

- See Note under **Flow Switches**

Motor amperage exceeds nameplate full load amps

- Impeller turning backward
- Airflow or static pressure change in ductwork
- Drains plugged
- Motor and RotoClone sheaves reversed
- Motor wired for wrong voltage

### 9.3 Auxiliary Impeller Flushing

An auxiliary flushing nozzle is supplied with a manual valve or automatic solenoid valve to provide extra cleaning for the impeller while it coasts down to a stop after the motor is de-energized.

**9.3A** The manual or solenoid valve should be piped up to the water line that supplies the RotoClone, after the strainer. The connection size is a ½" FPT on the valve.

**9.3B** The automatic solenoid valve option includes a timer/relay in a separate (shipped loose) box. Refer to the wiring diagram supplied with the unit for connection directions. The timer/relay is interlocked with the motor starter to open the solenoid when the “STOP” button is pushed. After the timer runs its preset time, the solenoid closes, shutting off water to the RotoClone.

**Note: The valve should not remain open while the RotoClone is running. The extra water may cause water entrainment in the exhaust airstream.**

