



AmericanAirFilter®
ArrestAll® AR Series

*Self-Contained
Shaker Type
Dust Collector*

ArrestAll® AR Series

Self-Contained Shaker Type Dust Collector

The ArrestAll dust collector is a compact and efficient solution to small and medium volume dry dust problems. Designed to control dust from a single source or system, the ArrestAll saves energy by recirculating clean air.

- Excellent filtration — AAF engineered envelope (pocket) filters remove up to 99% of general industrial dust by weight
- Self-contained operation — can be easily relocated
- Quiet operation — silencing included on every unit
- Low maintenance — self-cleaning with extra-large dust containers
- Compact design — conserves floor space, can be placed close to machinery
- Saves energy — cleaned plant air can be recirculated to reduce exhaust and energy costs
- Safer work environment — Improves Indoor Air Quality by removing airborne pollutants
- Rapid filter change and long filter life
- Durable powdercoat finish for indoor or outdoor service

Principles of Operation

- 1 Dust laden air is drawn into the inlet where it turns 90° causing the heavier particles to fall into the container.
- 2 The fine particles are drawn to the fabric pockets and trapped on the surface, forming a dust cake which increases efficiency.
- 3 The clean air flows from the pockets into the fan and is discharged.
- 4 The collected dust is periodically removed from the fabric pockets by an automatic shaker system.

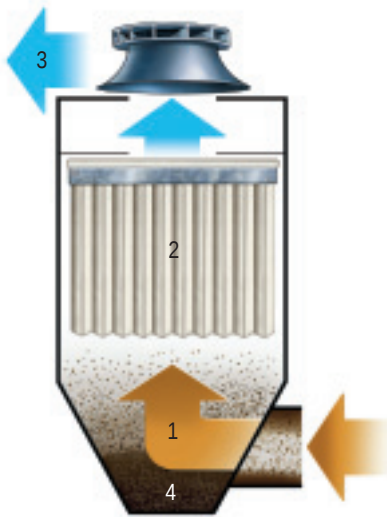

AR2 Funnel Bottom

Efficient Operation

AAF dust control experts designed the ArrestAll for many years of trouble-free, efficient service. The ArrestAll performs effectively in a variety of applications such as wood-working, grinding, polishing, packaging, and bin venting. Automatic off-line cleaning of filters is standard on all units.

World-Class Quality

Many of the technologies used to control air pollution were originally developed by AAF. Our facilities are specifically designed to manufacture and test complex air pollution control products. During the entire production process, our operations are governed by our ISO 9001:2000 certified quality system.

Superior Shaker Action

The ArrestAll shaker moves the filter envelope with the necessary acceleration and frequency to dislodge the dust cake, providing excellent filter fabric cleaning. Force is distributed throughout the fabric pocket by a shaker bar which holds each pocket and its internal separator framework.

Automatic shakers are standard on sizes AR1-3 through AR6-25. A micro-electronic controller is mounted and wired to the shaker motor. The controller is UL-508 and CSA approved.

Quiet – Meets OSHA Limits

ArrestAll collectors include silencing to comply with OSHA noise limits.

Dust Disposal Choices

Select the ArrestAll dust disposal arrangement that best fits your application. Model AR1 is available in flat bottom with drawer and funnel bottom. Model AR2 is available in flat bottom with drawer or carts or funnel bottom. AR4 and AR6 are available only with funnel bottom.

The flat bottom units include generously sized collector bins or carts. Access doors feature large, quick opening latches. The funnel bottom units fit 55-gallon drums.

High-Performance Fans

The non-overloading fan delivers more air at higher static pressures and reduces capacity variation and suction loss as the dust cake builds on the filter fabric.

With the fan on the clean air side, dust and other collected material are filtered out by the fabric filter before reaching the fan, resulting in long, reliable performance.

Filter Pocket Spacing to Match Applications

The ArrestAll filter is available with either standard or extra wide pocket spacing. The extra wide spacing is ideal for coarse or fibrous dust as found in grinding or woodworking applications. The standard pocket spacing is recommended for fine dust applications.

Features

TEFC fan motor, 3 phase, 208, 230, 460, or 575 voltages available

Horizontal fan outlet

Backward inclined fan

One piece cloth envelope filter

Automatic shaker motor

Large hinged lift off access door

Free flow steep funnel

Optional 55-gallon drum

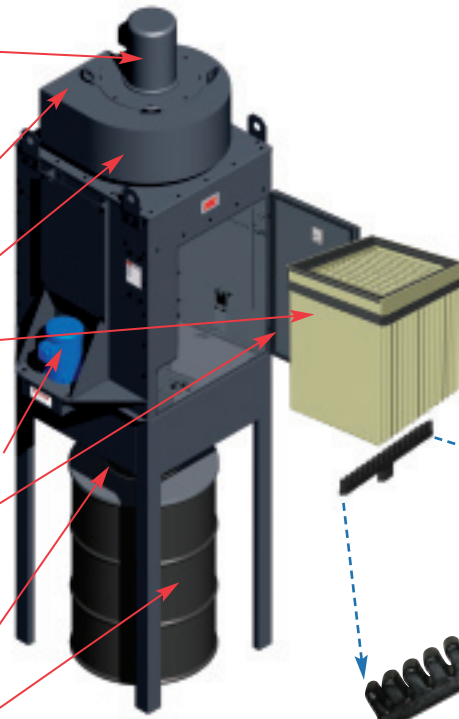

AR1 Funnel Bottom

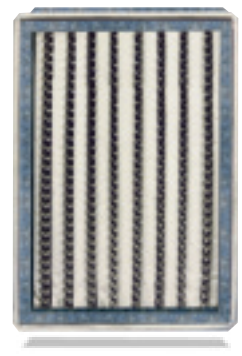

Optimized Filter Design

The ArrestAll filter has been designed to maximize airflow and efficiency. The pocket and separator geometry minimizes pressure drop. The one-piece construction adds strength and sealing integrity to achieve up to 99+% efficiency on general industrial dust by weight.

Smooth Flow Design

The ArrestAll filter design minimizes internal turbulence and pressure drop. Air flows vertically inside the filter pockets, guided by the corrugated spacers. This produces a laminar flow into the horizontal fan inlet cone.

Sizes AR1-3 thru AR2-10

ArrestAll sizes AR1-3 thru AR2-10 are compact, self-contained dust collectors. Available in bin vent, flat bottom, or funnel bottom dust disposal arrangements, each unit consists of a housing with fan, motor, filter envelope, and automatic shaker. The flat bottom unit offers the advantage of very low headroom, while the funnel bottom features the dust storage advantage of a single 55-gallon drum on AR1-3. Two drums are utilized with the AR2-5, AR2-7.5, and AR2-10. The bin vent model includes weather proofing with rain hood.



Innovative shaker system with patent-pending shaker comb

